

MORGAN YACHT - - THE COMPANY

Morgan Yacht, one of the country's leading manufacturers of fiberglass sailing yachts, was founded by Charles E. Morgan, Jr., in 1961. His famed 40 foot racing yawl "Paper Tiger", twice champion of the Southern Ocean Racing Conference (SORC), was the catalyst in getting the company underway.

During Morgan's formative years, it designed and built some of the world's largest and finest custom sailing yachts.

And in 1965, the company expanded its activities to include a series of production yachts, designed and engineered by then company president Charles Morgan.

These CCA type yachts found wide market acceptance, and the company underwent a period of rapid expansion Morgan became an established name in the yachting circle.

MORGAN -- A BEATRICE COMPANY

In 1968, Morgan Yacht was, acquired by Beatrice Foods Co. of Chicago, an international multi-billion dollar company that produces and manufactures more than 5000 products throughout the world. Although initially a food company, Beatrice has aggressively expanded into non-food products and today about 35% of the company's gross revenues are outside the food industry.

Beatrice Foods provided the financial strength that was heretofore lacking in Morgan. And in the fall of 1969, after the demand for Morgan yachts saw the original plant go through three expansion changes, the company moved into its new 150,000 sq. ft. manufacturing plant in Largo (St. Petersburg), Florida.

Today, the Morgan Yacht line consists of the "Out Island" series of cruising yachts. And a new series of yachts, now on the drawing boards, will more adequately meet the needs of all segments of the cruising market. The Morgan 45 and Morgan 38 are the first models of this series. Both are scheduled for introduction at the 1977 fall boat shows.

Morgan Yacht itself represents a smooth running, fully integrated yacht manufacturing and marketing organization. The staff includes a design section and a manufacturing/engineering section which are capable of full project engineering from concept through execution. Marketing representatives, headquartered at the main plant, not only service the Morgan dealers' needs, but through extensive travel and contacts in the yachting trade, keep the design section and general management abreast of the current trends in the yachting market.

In addition to strong financial backing, the company has a financial control system, which is unsurpassed in the industry. The cost accounting staff, assisted by computerized labor and material bills, is able to quickly and accurately determine costs of new products and product changes. Computerized cost control systems keep management constantly apprised of efficiencies in all phases of the operation.

Our physical plant includes not only the assembly lines and glass department, present in most yacht manufacturing facilities, but complete support groups as well. On-site shops produce all of the Spars, standing rigging, cushions, curtains, and mill shop joiner work components present on Morgan yachts. Because competent metal shops are available locally, much of our metal working is done externally. However, a complete machine shop is available in-house for those times when a delivery is late or a part must be changed for a specific application. These in-house capabilities allow Morgan to exercise maximum control of costs and end-product delivery schedules.

The Morgan plant also houses Ratsey and Lapthorn, one of the oldest and finest sail makers in the world, and a Ship's Store. These facilities allow the owner to fully equip his yacht prior to its leaving the plant.

The completeness of the Morgan plant and the wide range of staff capabilities have enabled the company to compete successfully for business outside our standard product line. The large watercraft at Disney world (submarines, one hundred foot plus paddle wheelers, steam launches, etc.) were all manufactured by Morgan Yacht.

More recently, Morgan Yacht won the contract to produce one-design 40 foot racing yachts for the North American Offshore One-Design Association (NAOODA), designed by Dick Carter. One-design requires maximum product equalization and control. NAOODA selected Morgan for its ability to produce, on schedule, high quality, carefully controlled racing yachts at a competitive price. Twelve of these yachts were sold to highly knowledgeable yachtsman before the first line was laid on the loft.

QUALITY

The quality and structural integrity of our yachts are the most important aspects of the manufacturing process. We hold to the premise that high quality is the end result of creative design, the proper application of materials and the skill and attitudes of the craftsmen building the yacht. Accordingly, we place a very high emphasis on these areas in our staffing and daily operations.

DESIGN

Quality in the end product begins in the yacht's design and development stages. At Morgan Yacht, the design phase for a new model is a long, involved process. We believe that time spent in the pre-production phases pays off many times over through the elimination of problems that could adversely affect quality in the production yachts.

A new model begins from a broad, conceptual definition provided by the marketing group. This is refined into specific design parameters only after long discussions involving retail buyers of Morgan yachts, Morgan dealers, and other individuals knowledgeable in the yachting trade, with Morgan marketing, design and management groups. The design group then goes to work to convert the design parameters into a tangible set of preliminary drawings and specifications. These are reviewed and modified by Morgan's Product Planning group and knowledgeable external sources. The process of review and revision occurs until Morgan management team is satisfied that the design represents the best possible solution to the market requirements.

Then the testing begins. This may involve tank testing at Stevens Institute to measure hull efficiency and/or the creation of a full-scale mock-up of the interior, cockpit, etc., to check the human engineering. The testing phase always involves a complete cost analysis, a thorough component-by-component value analysis, and a final review of the design and specifications by Morgan dealers.

Next, a prototype yacht is manufactured off-line. The manufacturing engineers, design engineers and quality control engineers work closely with the manufacturing team assigned to the prototype construction. All processes are carefully evaluated and when perfected, manufacturing procedures and specifications are documented. The prototype is then given extensive sea trial where any corrections are made. When the new model is finally ready for production, it represents the best-combined efforts of its marketers, designers, builders, sailors and inspectors.

SKILLED CRAFTSMEN

High quality production depends upon high caliber, highly motivated craftsmen. And our Morgan craftsmen have proved themselves time and time again. At our plant in Largo, Florida, we've brought together a staff of the most capable, experienced and painstaking boat builders in the world. The men who build Morgan's get involved in each boat on a personal level. They know how to translate "quality" into a fine partnership of skilled hands, sharp eyes and stored experience. The superb detailing you see in our custom interiors is your clue to the care that went into the structure you can't see.

Morgan management is ever aware of the importance of employee attitude as an influence on product quality and integrity. Our craftsmen are encouraged to contribute ideas through informal channels or the Suggestion System. Indeed, some of our most creative ideas have come from those actually building the yachts. Our craftsmen are provided with the proper tools and top quality materials. Professional supervisory training programs have been instituted for all employees in a supervisory capacity. A company yacht is almost always available to the employees to allow them to experience first hand the joys of sailing and to visualize how their specific input affects the end result. Employee security has improved greatly over the past few years through the elimination of rapid increases and decreases in production levels and the resulting lay-offs. The above, coupled with above average pay rates and benefits, has allowed Morgan to attract and retain capable, productive craftsmen throughout the shop. Employee satisfaction is evidenced in our end product.

MATERIALS

Quality is also strongly affected by the proper selection and application of materials and component parts. Material and process evaluation is a continuous endeavor at Morgan Yacht.

A materials testing laboratory is used for evaluation. New processes are tested both in the laboratory and in the various shops under the careful scrutiny of engineers and technicians. While innovation and improvement are strongly encouraged, no change is introduced in production yachts until it has been carefully pre-tested. Strict adherence to this principle has, for the most part, eliminated the "catastrophes". As a result, the company has little fear in using "the new" -- providing it is pre-tested in-house.

Some recent advancements in material application include the use of high density syntactic foams as rudder and deck coring, the development of a means to impart fire redundancy to resins without the negative side effects of high cost and toxic gas emission upon ignition, and the use of a glass peening process -- a technique used in the aircraft industry to temper aluminum -- in the finishing of spars. We were among the first to capitalize on the advantages of Airex foam coring in large production yachts. Morgan also worked with DuPont in evaluating aliphatic urethane as a marine finish -- seven years before its current widespread acceptance.

Our testing programs have also helped us avoid some "innovations" used elsewhere, which we believe present unacceptably high risks. For example, all glass components are fully hand laminated. Chopper guns save labor and material cost, but result in significant loss of control of laminate thickness. This becomes important when you realize that a laminate 25% under design thickness (imminently possible with a chop gun) has only 56% of design breaking strength and 42% of design stiffness. We have also foregone the cost savings available through full fiberglass interiors. Aside from the effect on appearance, full glass interiors often interfere with the structural support available through bulkheads, which are fully fiber glassed, bonded to the hull.

VALUE ANALYSIS

Morgan Yacht has a formal value analysis program which is essentially a continuous review of our existing product line and all materials, components and processes used in their construction. The goal of this program is to maximize “value” in the finished yacht. Each current component of construction is measured against possible alternatives in the areas of effect on finished yacht quality, performance and cost. This process helps us keep our yachts at a “state of the art” level while at the same time maintain a competitive pricing structure. Accomplishing one or the other is comparatively easy. Our goal is to accomplish both simultaneously.

QUALITY CONTROL

We view quality control as being analogous to financial control. A good system will detect and measure strong and weak points, and this is extremely important. It will not, however, in itself correct problems. Quality control must be viewed as a tool to assure that the intended product attributes are present, period.

We are one of a few sailboat manufacturers who test all systems of each and every yacht in a pool. All decks are tested under a fire hose for leaks. The Morgan laboratory tests incoming resins, gels, fiberglass and adhesives for compliance to material specifications. The laboratory also routinely checks glass contents of thru-hull plugs taken from production hulls. Each yacht is checked by a trained inspector at several points during construction. Engines and other mechanical/electrical components are bench tested prior to installation. And the final inspection of each yacht is an exhaustive review of all aspects of the finished product, including loose gear packed after completion.

We are currently developing programming which will allow the computer to generate check-off inspection sheets tailored to each specific yacht and its combination of systems -- a system we believe to be unique in the yacht industry.

WARRANTY

Backing up our product is a clear and comprehensive warranty program, administered through the Morgan Warranty Department. Valid warranty claims are promptly approved and paid for by the company.

TESTIMONIALS

"Another testimonial for a Morgan OI 41. My wife Jo and I sailed from Lake Ontario to Cape Cod the end of September, then on down to Norfolk and through the Intracoastal to Morehead City for the take off to the Bahamas. I heartily recommend to everyone going to sea for their education to take an experienced teacher like our OI 41. She was a really kind of forgiving boat to bring two innocents afloat into port safe and sound.".. .J.T.F.

"I have just returned from delivering the Morgan Out Island 41 'Libra' from Lymington to Southern Portugal and felt I must let you know how impressed I am with her performance, comfort and good design. The trip of just under 1,000 miles took 7 days - very good for a roomy, comfortable cruising boat. The whole crew (6) decided that it had been a very enjoyable and trouble free trip. I decided that I would quite happily deliver a Morgan Out Island 41 anywhere in the world" . . .A.W.R.

"My wife and I took possession of our Morgan Out Island 51 in Clearwater. We have lived aboard the boat constantly. Last summer we spent a month in Maine, plus a week or two on Buzzards Bay, and since then we brought her back to Florida, making much of the trip outside, and on one leg we encountered a 45 knot gale, so we feel we have experienced pretty much every kind of condition one can expect to meet with a cruising boat of this type"... A.D.M.

"I am the owner of a Morgan Out Island 41 yacht. I have had occasion, twice, to have warranty repair work done on the hull and engine bed. All of these repairs were performed on a three-year old boat, for which the warranty had long since expired. In my opinion this was above and beyond any necessary action".... J.B.Y.

"Considering the rough seas and high wind factor, the OI 41 handled beautifully. She was all the boat we thought she was and more. This is my third Morgan sailing vessel; you build the finest in its class"..... J.F

CONTENTS

	<u>Page</u>
I. Foreword	IA
A. Welcome	
B. Purpose and Scope of Owner's Manual	
C. Sources of Additional Information and Parts	
II. Specifications	
A. Design Concept	IIA
B. General Design Specifications	IIB
C. Standard Equipment	IIC
D. Serial Numbers	IID
E. Manufacturer's Document	IIE
F. Procedures and Data for Documentation	IIF
III. Commissioning and Decommissioning	
A. Initial Commissioning	IIIA
Receiving and Commissioning Check List	IIIA-3
B. Decommissioning for Storage (Winterizing)	IIIB
C. Recommissioning After Lay-Up	IIIC
D. Hauling and Cradling	IIID
IV. Operating Procedures	
A. Tips on Sailing the Out Island 41	IVA
B. Spars and Rigging	IVB
1. Stepping the Mast and Dockside Tuning	IVB
2. Tuning under Sail	IVB-1
3. Halyards and Outhauls	IVB-2
4. Quick Reefing	IVB-3
C. Engine	IVC
1. Pre-Starting Check Off	IVC
2. Starting Procedures	IVC
3. Engine Operation	IVC-1
4. Engine Shutdown	IVC-1

	<u>Page</u>
IV. Operating Procedures (continued)	
D. Fuel System	IVD
E. Electrical System	IVE
1. Batteries	IVE
2. Alternator	IVE
3. Starter	IVE-I
4. Battery Switch	IVE-J
5. Electrical Panel	IVE-1
6. Pedestal Switches	IVE-2
7. A.C.110 Volt Shore Power System	IVE-3
8. Battery Charger Option	IVE-4
9. A.C Generator Option	IVE-5
F. Plumbing System	IVF
1. Thru-Hull Connections	IVF
2. Fresh Water System	IVF-1
3. Bilge Pumps	IVF-2
4. Sump Pump	IVF-2
5. Marine Heads	IVF-2
6. Holding Tanks	IVF-3
7. Optional Dockside Water Supply	IVF-3
G. Refrigeration	IVG
1. IceBox	IVG
2. Ice Maker Option (Icerette)	IVG
3. Norcold Refrigeration Option	IVG
4. Grunert Refrigerator	IVG-1
H. Optional Air Conditioning (Marinaire)	IVH
I. Alcohol Stove	IVI
1. Fueling	IVI
2. Operating	IVI
3. Shut Off	IVI
4. Miscellaneous	IVI-1

IV.	Operating Procedures (continued)	
J.	Opening Ports and Hatches	IVJ
	1. Ports	IVJ
	2. Hatches	IVJ
K.	Navigation Lights	IVK
V.	Maintenance Procedures	
A.	Engine	VA
	1. Break-in Period	VA
	2. Before Each Outing	VA
	3. Every 150 Hours or 3 Months	VA
	4. Every 450 Hours or 12 Months	VA-I
	5. Every 2400 Hours	VA-I
	6. Bleeding the Fuel System	VA-I
B.	Drive Train	VB
	1. Engine Alignment	VB
	2. Transmission	VB-1
	3. Intermediate Bearing	VB-2
	4. Stuffing Box	VB-2
	5. Optional Shaft Lock	VB-3
C.	Exhaust System	VC
D.	Steering System	VD
	1. Stuffing Box	VD
	2. Gudgeon Assembly	VD
	3. Hydraulic Steering System	VID
E.	Electrical System	VE
	1. Preventive Maintenance	VE
	2. Repair	VE
	3. GFCI Protection	VE-2
F.	Cathodic Protection	VF

	<u>Page</u>
V. Maintenance Procedures (continued)	
G. Deck Hardware	VG
1. Winches	VG
2. Blocks	VG
3. Lifelines	VG
4. Deck Hardware Mounting	VG-1
5. Roller Furling Gear	VG-1
6. Running Lights	VG-2
H. Spars and Rigging	VH
I. Finishes	VI
1. Fiberglass	VI
2. Vinyl Hull Liner and Bulkhead Covering	VI-2
3. High Pressure Laminate Surfaces	VI-2
4. Upholstery Fabrics	VI-2
5. Spars	VI-3
6. Aluminum Hardware	VI-3
7. Stainless Steel Rigging and Hardware	VI-4
8. Chrome Plated Bronze Hardware	VI-4
9. Boot and Sheer Stripe	VI-4
10. Bottom Paint	VI-4
11. Lexan and Plexiglass	VI-5
12. Teak Joiner work	VI-6
J. Sail Care	VJ
VI. Charts and Drawings	Appendix
Profile (Sloop)	a
Profile (Ketch)	b
Interior Accommodations	c
Deck Arrangement (Sloop)	d
Deck Arrangement (Ketch)	e
Standing Rigging (Sloop)	f
Standing Rigging (Ketch)	g
Main Mast	h
Mizzen Mast	i

	<u>Page</u>
VI. Charts and Drawings (continued)	Appendix
Main Boom	j
Mizzen Boom	k
Main Sheet Arrangement (Sloop)	l
Main Sheet Arrangement (Ketch)	m
Quick Reefing System	n
Mizzen Staysail Package	o
Hauling Diagram	p
Roller Furling Gear	q
Working Jib Gear Package	r
Electrical Schematic (12 vdc)	s
Electrical Schematic (AC Wiring Twin Circuit w/Onan)	t
Electrical Schematic (Pedestal)	u
Electrical Schematic (110 vac)	v
Fuel System	w
Water System	x
Navigation Lights	y
Major Component Location	z
Terminal Identification	aa
Required Safety Gear	bb
Table of Fuses and Bulbs	cc
Recommended Reading	dd

I. FOREWORD

A. Welcome!

With your purchase of your new Morgan Yacht, you became a member of a large fraternity of Morgan owners. Welcome to the group!

Over the years, more than 4,000 Morgan yachts have been produced and sold. We have maintained contact with many of the owners and users of our yachts. Feedback from them has been extremely useful in our continual upgrading of our product. This feedback, coupled with our internal R & D programs and the application of new technologies developed in the marine industry and related industries, is reflected in your yacht's design and construction. We believe that your yacht represents the current "state of the art"; and, we believe she will satisfy your expectations with respect to aesthetics, function, and safety.

Morgan Yacht is committed to producing and marketing the best value in sailing yachts available in the world. While each person's concept of value varies, factors generally considered are quality of design and workmanship, performance, safety, aesthetics, purchase price, and resale value. The weighing of these factors differs by individual and over time. We welcome your assessment of our product. Input from you will help us measure and, if necessary, change the balance of priorities assigned to our product.

We wish you many happy years of sailing with your new yacht, and

LET'S KEEP IN TOUCH!

MORGAN YACHT

B. Purpose and Scope of Owner's Manual:

The purpose of the Owner's Manual is to provide you with the following information:

1. General operating procedures for your yacht and all of the factory installed systems.
2. General maintenance procedures.
3. Specifications, drawings, and schematics on the yacht, her components, and her systems.

Volumes could be written on the operation, maintenance, and repair of your yacht and her systems. To keep the text manageable in terms of readability and easy reference, much of the detail has been omitted. Supplementing the text, you will find separate manuals for most of the major equipment in your yacht. The separate manuals, coupled with the general text and drawings provided in the Owner's Manual, should allow you or your yard to diagnose and correct most problems you are likely to encounter.

We encourage you to first study the Owner's Manual carefully and then to read the various equipment manuals. This will provide you with an understanding of the basics and a knowledge of where to locate specific details.

Discussions on navigation and general boat handling are beyond the scope of the Owner's Manual. Information on these extremely important areas is available in numerous publications. A list of recommended reading is included in the last section of the manual.

Morgan Yacht continually upgrades its product. Every effort is made to update the Owner's Manual to reflect these changes, and the manual is believed to be current at the time of printing. If, however, you find a discrepancy between the manual and the yacht, consult your dealer before operating the system in question.

C. Sources of Additional Information and Parts:

Morgan Yacht dealers have been selected on the basis of their knowledge in the marine field. In most cases, your dealer will be able to answer questions which arise and are not covered in the manual. He can also obtain replacement parts for you from Morgan Yacht. You should contact your dealer first for information or repair parts.

Morgan Yacht has three internal service groups to assist you with problems the dealer is unable to resolve. All are located at the main plant at 7200 Bryan Dairy Road, Largo, Florida, 33543. The phone number is (813) 544-6681. Their functions are described below:

Warrant Department: Provides information on warranty policy and administers warranty work.

Customer Service Department: Provides general and technical information on Morgan products.

Ship's Store: Supplies repair parts, retrofit kits, and general marine gear (hours 10:00 to 5:00, Monday thru Friday)

II. SPECIFICATIONS

A. Design Concept:

The Out Island 41 was first conceived in January 1971 as the first of a new line of cruising yachts by Morgan Yacht. This design was Morgan Yacht's first departure from the then popular CCA (Cruising Club of America) class of cruising/racing sailboats. Unlike the CCA boats, the Out Island family was not held to restrictions imposed by any racing handicap rules. Instead, the design parameters were defined by a careful balancing of priorities as they related to the yacht's primary function - comfortable short range and/or extended cruising. In addition, the yacht had to be aesthetically pleasing.

While the Out Island 41 concept was formulated over five years ago, it continues to be popular today. The yacht has been refined over the years. Ideas from owners, new innovations in materials and equipment, and federal and maritime regulations are a few of the influences on the continual upgrading. Today, the Out Island 41 is contemporary in both concept and detail.

Major features in the design of the Out Island 41 are:

1. Shoal draft without the usual problems associated with centerboards, but accepting some compromise in windward performance.
2. Maximum usable space above and below decks
3. Dedicated to the preservation of aesthetics

The basic approach to styling was to maintain a low profile without the traditional high trunk cabin. This was accomplished by using a modified flush deck design. A low sheer line was created by the rub rail detail and contrasting whale stripe. The result is a low appearing freeboard with an actual positioning of the weather deck well above the waterline.

Maximum interior space was accomplished primarily through wide beam. The beam to length ratio of the Out Island 41 is .34. (Most sailing yachts center around .30). The maximum beam also provides good hull form stability which is important in cruising sailboats, especially those with shallow draft.

The wide beam provides more than the usual amount of clear deck space and room for a large center cockpit. The center cockpit allows space below for a large engine room amidships.

This engine room location provides a substantial physical separation of the aft stateroom and the main salon, resulting in a high degree of privacy for a yacht of this size.

The raised flush deck and center cockpit offer a very high degree of visibility in all directions, under sail or power. And, the deck surfaces are clear and high out of the water, making topside work easier and safer in rough weather.

B. General Design Specifications:

Length Overall	41' 3"
Length Waterline	34' 0"
Beam	13' 10"
Draft	4' 2"
Displacement	27,000 lbs.
Lead Ballast (internal)	9,000 lbs.
Sail Area (Sloop)	
100% Fore Triangle	416 sq. ft.
Mainsail	254 sq. ft.
Sail Area (Ketch)	
100% Fore Triangle	416 sq. ft.
Mainsail	254 sq. ft.
Mizzen	122 sq. ft.
Standard Engine	62 H.P. Perkins
Fuel Tankage (Aluminum Tank)	138 gallons
Water Tankage (2 Aluminum Tanks)	170 gallons
Vertical Clearance	53 ft.

OUT ISLAND 41 (415) STANDARD PACKAGE YACHT

HULL

Solid fiberglass hand lay-up laminate, substantially reinforced in way of keel and all chain-plates

Internal cast lead ballast securely fiberglassed into molded keel

Hull color white, with contrasting boot and sheer

Full-length solid molded rub rail with aluminum cap

Bronze thru-hull fittings with valves

Structural non-corrosive heavy wall fiberglass shaft log

Interior wood construction treated with wood preservative below cabin sole

DECK & EXTERIOR HARDWARE

Deck color white with molded-in contrasting color non-skid

Deck, cockpit and cabin are a plywood-cored sandwich construction, fully hand-laid with mat and roving into a single fiberglass molding

Aluminum anchor roller chock assembly with large roller

Pulpits are all stainless steel welded construction

Stainless steel lifeline stanchions w/vinyl coated stainless steel double lifelines

Lifeline gates port and starboard

Deck hatch forward - white acrylic with neoprene gasket

Galley hatch aluminum framed tinted Lexan

14 opening ports w/Lexan glazing, non-corrosive frames, integral sill drains and screens

Two transom-opening ports with screens

Two fiberglass companionway hatches w/teak inlays

Teak companionway drop-in beards fore and aft

Fiberglass seat locker

Fiberglass helmsman's seat over beverage locker

5" Danforth illuminated compass w/sun shield

Teak deck handrails Full-length aluminum toe rails, slotted for infinite adjustment of genoa block location

35# CQR Plow anchor w/ground tackle

INTERIOR

Two double private staterooms

Forward stateroom with over/under berth combination, hanging locker and drawers

Aft stateroom with double berth, two hanging lockers, linen locker, bureau and dressing seat

Main salon with L-shaped dinette and settee opposite

Bulkhead-mounted folding dinette table

Settee convertible to sea berth w/padded bunk board

Dinette area converts into double berth

Two full-length shelves and storage locker in main salon

Teak interior trim and handrails

Mildew-resistant and fire-retardant vinyl hull liner and partition covering.

Vinyl lined lockers.

Large mirrors in both heads

Teak companionway ladders to main and aft cabins

Both heads w/separate shower areas and fiberglass shower pans

Custom fabricated 4" foam cushions w/deluxe color coordinated fabrics

Teak and holly sole in galley and main salon

Carpet in private staterooms and passageways

Teak veneer paneling on main bulkheads & vertical surfaces

Draperies standard on all opening ports except transom

Teak chart table with 7 cu. ft. ice box, drawers and chart stowage below. Shelf above chart table w/space available for electronics. Chart table adjacent to main companionway

Large engine room with maximum access to machinery

Double engine room access doors - removable

Hand rubbed penetrating sealer on all teak-surfaces

GALLEY

Large L-shape galley with bulkhead forming third side of "U"

Two burner stainless steel alcohol stove w/oven and gimbals

Double stainless steel sink

Emergency fresh water hand pump on galley counter

Ten cu. ft. icebox, top-loading with flush mounted

Drawer and compartmentalized shelf storage outboard of stove and over counter

Dry food storage locker under companionway ladder

Mica on counter surfaces

Hand pump drain for each icebox under galley sink

RIGGING

Sloop rig w/complete standing and running rigging - all wire rope stainless steel

Mast and boom - one piece aluminum extrusions w/maximum corrosion resistant satin-peened finish

PVC wiring conduit w/messenger inside mast

Aluminum airfoil section spreaders

Boom w/fixed gooseneck

Schaefer roller furling gear

SAIL HANDLING EQUIPMENT

Two 2-speed Lewmar 43 sheet winches

One 2-speed Lewmar 16 mainsheet winch

Two 2-speed Lewmar 16 mast-mounted halyard winches

Two 10" winch handles

Two soft-shell snatch blocks for genoa sheets

Deck-mounted genoa turning blacks

Main boom topping lift.

PROPULSION, STEERING & CONTROLS

Perkins 4-154 (62 hp) diesel engine w/2.57:1 reduction gear and fresh water cooling

1.25" diameter Sealoy propeller shaft

Three-bladed bronze propeller

Pedestal mounted engine controls and instruments including tachometer, oil pressure and water temperature gages, ammeter and hour meter

Pedestal mounted Hynautic hydraulic steering unit w/stainless steel destroyer wheel

Fiberglass rudder with 1-3/4" diameter stainless steel shaft and 3/8" gudgeon plate.

Rudder is cored w/syntactic polyester foam for light weight, high strength & maximum adhesion to rudder skins

Deck lights, navigation lights, bilge pump & engine room blower controlled from steering pedestal

PLUMBING SYSTEMS

Pressure water distribution system w/rigid heavy wall PVC plumbing and filter at pump

Hot water heater - 6 gal. Raritan w/engine by-pass & 115 vac element

Marine heads w/manual pump to holding tanks or direct overboard discharge.

Holding tanks plumbed to deck plate.

Water tankage - 170 gal. in 2 welded aluminum baffled tanks

Fuel tankage - 138 gal. in single welded aluminum baffled tank

1200 gah submersible 12 volt bilge pump

4.5 gpm 12 volt shower pumps

ELECTRICAL SYSTEM

All BIA color coded wiring

All interior circuits (except engine) wired thru 1 main junction panel

Custom 115 v. AC/12 v. DC modular electric panel

Hydraulic/magnetic breakers (MIL spec) w/"on-off" indicator lights in lieu of fuses in main panel

115 vac., 30 amp shore power w/50 ft. cord and adaptor

115 vac, duplex receptacles throughout

Marine batteries - two 155 amp hr - 12 volt

4-position vapor-proof master battery switch

12 volt lighting throughout

12 volt, 150 cfm engine room blower

12 volt navigation lights including running lights, masthead light, foredeck light controlled at pedestal

D. Serial Numbers:

Hull Number (Coast Guard)

Engine Serial Number

Generator Serial Number

Hot Water Heater Serial Number

Stove Serial Number

Battery Charger Serial Number

Icemaker Serial Number

Refrigerator Serial Number(s)

Stereo Serial Number

E. Manufacturer's Document:

For every yacht manufactured by Morgan, a Master Carpenter's Certificate (MCC) and Manufacturer's Statement of Origin (MSO) are prepared upon request. Both the MCC and MSO must be prepared with the name of the dealer to which the yacht was originally sold. The dealer, then, upon payment in full, endorses these documents over to the person to whom the yacht was sold. The MCC is used for U.S. Coast Guard documentation, and the MSO is the title to the yacht and used for state registration.

Morgan Yacht can issue only one original MCC and MSO. If they become lost, no duplicate will be issued by Morgan Yacht. However, if you wish to document your yacht, and the MCC has been lost; Morgan Yacht can issue a letter. This will enable you to proceed with documentation of your yacht with the U.S. Coast Guard.

F. Procedures and Data for Documentation:

Documentation must be accomplished with the United States Coast Guard in the United States or with the governing agency in the country where your vessel is to be registered. We suggest you contact the Documentation Office nearest you for full details, forms, and instructions.

The following notes and references are made for your information and convenience. They should in no way be misconstrued as complete and detailed instructions.

Procedure:

Pleasure Class - Under 20 tons requires a Yacht License. Twenty tons and over requires a Certificate of Enrollment and a Yacht License.

Application for Admeasurement - Requires a Master Carpenter's Certificate issued by the builder on the prescribed Coast Guard form. This certificate will be retained by the Coast Guard with certified copies available to the owner.

Admeasurement - The admeasurer uses data on the Master Carpenter's Certificate (MCC) to compute net tonnage. The following formulas are used for sailboats:

$$\text{Gross Tonnage} = 1/2 (\text{LBD}/100)$$

$$\text{Net Tonnage} = .9 (\text{Gross Tonnage})$$

where

L = Length

B = Breadth

D = Depth

Official Number - After admeasurement files your certificate of tonnage, application is made for an official number. Title and mortgage papers are required.

Additional Forms - Application for Number Declaration of Ownership and/or Extent of Interest Identification of Owner's or Existing Mortgages

Declaration of No Foreign Interest Involved
Designation of Master of Vessel
Declare No Freight or Commercial Passengers to be Carried on Board
Designated Home Port - Licensing Office
Designated Hailing Port - Berth Marking Certificate

Commercial Class - Contact your U.S. Coast Guard Documentation Office for information, due to the complexity of application.

For your information and reference, the next two pages contain sample copies of actual MCC's and MSO's containing the vital information on your boat.

Them forms are signed by Morgan Yacht with the authorized signature and title of the person or responsibility, and are notarized.

Several magazine articles have been written on the subject, which may be of assistance to you in your application. Reprints of these articles should be available from the various yachting and boating magazine publishers.

Morgan Yacht Corporation

7200 BRYAN DAIRY ROAD • LARGO, FLORIDA 33540 • 813-544-6681

MANUFACTURERS STATEMENT OF ORIGIN TO A BOAT SOLD IN THE

The undersigned manufacturer hereby certifies that the new boat described below, the property of said manufacturer, has been sold this _____ day of _____, 19 _____ on

Invoice No. _____

Dealer's Name _____

Address _____

City, State and Zip Code _____

Model Year _____ Serial No. of Boat _____

Hull Length 41 ft. 3 in. Beam 13 ft. 10 in.

Hull Material: Wood Aluminum Steel Fiberglass

Type Boat: Outboard Inboard Sail Other

This form shall be presented with application for Florida title.

The manufacturer certifies that all information given herein is

true and accurate to the best of his knowledge.

FIRM NAME _____

BY _____

Authorized Signature

TITLE OR POSITION _____

Before me personally appeared _____

who by me being duty sworn upon oath says that the statements set forth above are true and correct subscribe and sworn to before me this _____

day of _____, 19 _____

Notary Public

(SEAL)

Date Commission Expires _____

Morgan Yacht Corporation

7200 BRYAN DAIRY ROAD • LARGO, FLORIDA 33540 • 813-544-6681

MASTER CARPENTER'S CERTIFICATE (BUILDER CERTIFICATE)

<small>Place</small> Largo, FL 33541	<small>Date</small> Current Date	<small>Name of Master or Principal Carpenter</small> Doug Franzese
<small>Address</small> 7200 Bryan Dairy Road, Largo, FL 33541		
<small>RIG</small>		<small>Hull No.</small>

VESSEL WAS BUILT (Insert "By me" "Under My Direction" "By _____" living Name or corporate name, if applicable)
By Morgan Yacht

<small>YEAR OF COMPLETION</small>	<small>PLACE WHERE BUILT</small> Largo, Florida 33541 U.S.A.	<small>MATERIAL OF HULL</small> Fiberglass
-----------------------------------	--	--

NAME OF PERSON OR PERSONS FOR WHOM AND INDIVIDUAL INTEREST OWNED

Dealer Name and Address - Individual Interest Owned 100%

<small>NUMBER OF DECKS</small> 1	<small>NUMBER OF MASTS</small> 1 (Sloop) 2 (Ketch)	<small>CONTOUR OF STEM</small> Clipper	<small>SHAPE OF STERN</small> Wine Glass
<small>LENGTH OF VESSEL</small> 41 2.5/10 ft /10 FEET	<small>BREATH OF VESSEL</small> 13 8/10 ft /10 FEET	<small>DEPTH OF VESSEL</small> 9 1/10 ft /10 FEET	
<small>GROSS TONNAGE</small> 21.97	<small>NET TONNAGE</small> 19.77		

THE FOLLOWING ADDITIONAL PARTICULARS SHALL BE GIVEN FOR THE ENGINE OF MACHINERY-PROPELLED VESSELS

TYPE OF ENGINE (Reciprocating, steam, turbine, etc. If steam, oil, gas, etc. if internal combustion)
Diesel (Standard)

<small>PLACE WHERE BUILT</small>	<small>YEAR BUILT</small>
<small>BUILT BY</small>	
<small>POWER (Steam, heavy oil, light oil, gasoline, etc)</small> Diesel	

I certify that the information given above is true and correct to the best of my knowledge and belief.

<p>Before me personally appeared _____ Who by me duly Sworn upon oath says that the statements set forth above are true and correct. Subscribed and sworn to before me this _____ day of _____, 19____ _____ (SEAL) Notary Public Date Commission Expires _____</p>	<p style="text-align: center;">SIGNATURE OF MASTER CARPENTER OR BUILDER</p>
---	---

SAMPLE COPY ONLY – NOT TO BE TRANSFERRED

III. COMMISSIONING and DECOMMISSIONING

A. Initial Commissioning:

The commissioning of your yacht is an owner's responsibility. Your dealer may be able to provide you with this service at his yard or recommend a yard which is competent in commissioning Morgan Yachts. We strongly recommend that you have the initial commissioning performed by a yard that is experienced in sailboats and, preferably, Morgan sailboats.

The initial commissioning is extremely important. In addition to putting the yacht into service, the following functions are also served:

- Shipping damage is revealed. The trucking company is liable for shipping damage. They require prompt notification of any claims against them.
- Part shortages are revealed. Morgan boxes the loose gear and provides an indexed packing list. We do occasionally make errors. It is much more convincing to us that the error is ours, if we are notified before the yacht is sailed. One owner claimed that he was short shipped a stanchion and that this was first discovered six months after launch!
- Quality defects are revealed. Your yacht is thoroughly checked at the plant. Our quality program for each yacht includes a pool test, water drench test, functional testing of all systems, and visual checks of the entire yacht. However, overland travel often causes leaks and other problems which are difficult to detect by visual inspection alone. Also, we occasionally miss something. As with claims of short shipments, early notification to the factory adds credibility to the claim of a quality defect.
- Perkins delivery check-out service is performed. This is extremely important. This service is provided free of charge to you by Perkins. You should request this service from the local Perkins representative before 50 hours are recorded on the hour meter. The Perkins representative will check the engine, provide operating information, describe how to obtain service on the engine, and put your engine warranty into effect. If at all possible, you should plan to be present during the check-out so that the Perkins representative can familiarize you with the engine.

The following functions should be performed during the initial commissioning. Detailed procedures are described in their respective sections of this manual.

1. Inspect hull, deck, rudder, propeller and shaft, and spars for shipping damage.
2. Inventory all loose gear and report shortages or damaged parts.
3. Install thru-hull fittings for owner and/or dealer supplied equipment.
4. Paint bottom. For maximum anti-foulant life, a full second coat of bottom paint is recommended.
5. Launch and inspect all underwater fittings for leaks.
6. Fill fuel, water, and alcohol tanks and search for leaks. Caution: Be sure to bleed hot water heater before turning on the 110 v. element. The element will burn out immediately if energized in a dry or partially filled tank.
7. Install pulpits, stanchions, and lifeline wires. Safety wire lifeline ends and gates.
8. Install standing and running rigging on mast. Check mast wiring and lights. Record rigging lengths from tags supplied. (See following check list.)
9. Step mast(s), set up and adjust rig, pin and tape all turnbuckles, check halyards, and install mast boot(s).
10. Reeve sheets, bend on and hoist sails. Furl sails and install sail covers.
11. Connect prop shaft coupling. Align engine to .002" max. clearance. Note: The coupling was disconnected at the plant after alignment check in the pool. This is necessary to prevent damage to the drive train during overland shipment, hauling and/or launching.
12. Check oil and water level in engine and generator.
13. Complete installation of owner or dealer supplied equipment.
14. Check battery condition and re-charge, if necessary.
15. Perkins delivery check-out service.
16. Check operation of all systems and equipment.
17. Check all doors and drawers for proper movement and secure latching.
18. Water test deck, fittings, and ports and search for leaks.
19. Sea trial under power and sail.

20. Recheck for leaks in interior plumbing systems (fuel, water, and waste) and exterior hardware.
21. Complete Commissioning Certificate and Inspection Report and return to Morgan Yacht.
22. Clean interior and exterior of yacht thoroughly.

The next few pages provide you with a check list used by some of our dealers to inspect and commission Out Island 41's. Your completing this check list will provide you with a "condition report" of the boat before and after initial commissioning.

Note: Your yacht may have been partially winterized at the plant. Drain plugs will be placed in the galley sink. Replace all drain plugs prior to launching the yacht.

Receiving and Commissioning Check List
(For Owner's Records)

Delivery Inspection

- Boat properly cradled
- Spars properly cradled
- Free of sideswipe damage
- Free of bridge damage
- Companionway seals unbroken
- Absence of ext. hardware theft
- Loose gear inventory complete

Pre-Launch Inspectors

- Road dirt removed
- Bottom paint touched up
- Propeller secured properly
- Rudder moves freely
- Prop shaft turns freely
- All below waterline fastenings are tight
- All plumbing to thru-hulls connected and securely fastened
- All thru-hull valves closed
- All drain plugs and petcocks closed

Launching Inspection

- Boat properly slung during launch
- No damage during launch
- Thru-hull fittings leak free
- Rudder bearing leak free
- Shaft log leak free
- Shaft packing nut adjusted to 1 drop/30 seconds with engine off
- Thru-hull valves, connecting and plumbing leak free with valves open

YES	NO	CORRECTED

Engine Installation

- All mounting bolts tight
- Engine aligned to .002 max. clearance
- Coupling bolts tight
- Shaft set screw tight and secured with
Safety wire
- Intermediate bearing greased
- Crankcase oil level full
- Transmission gear box oil level full
- Throttle/shift linkage secure
- Engine stop connection secure
- Drain plugs installed and petcocks closed
- Cooling water level full

Tankage and Plumbing Connections

- Fuel tank and lines leak free
- Water tanks and lines leak free
- Alcohol tank and lines leak free
- Alcohol pump functions properly
- Alcohol tank retains pressure

Pulpits and lifelines

- Pulpits and stanchions secure
- Lifelines properly tensioned
- Lifeline end fittings safety wired
- Gates function properly
- Lifeline wires free of physical damage

YES	NO	CORRECTED

Spars and standing Rigging (Pre-Stepping)

- Mast(s) free of physical damage
- Boom(s) free of physical damage
- Rigging free of physical damage
- Mast wiring and lights functional
- Masthead pins secure and sheaves free wheeling
- Standing rigging and topping lift properly Fastened to spar and pinned
- Halyards installed
- Spreaders fit and properly secured
- Sail track free of burrs
- All fasteners tight
- Standing rigging lengths recorded below:

YES	NO	CORRECTED

	Length on Morgan Tag	Actual Length
Headstay Backstay Port Main Shroud Starboard Main Shroud Port Forward Lower Starboard Forward Lower Port Aft Lower Starboard Aft Lower Ketch-Port Backstay Ketch-Starboard Backstay Ketch-Port Main Shroud Ketch-Starboard Main Shroud Ketch-Port Lower Ketch-Starboard Lower Ketch-Triatic		

SPARS and Rigging (After Stepping)
 Standing rigging adjusted
 Turnbuckles pinned and taped
 Boom fits
 Spreader angle correct
 Winches run free
 Sails fit and slide freely
 Outhaul installed and functional
 Jiffy rigging rigged and functional
 Haylards function properly
 Furling gear operates properly
 Mast boot installed
 Mast lights operational

Batteries Fully Charged

Perkins Delivery Service Completed

Hydraulic Steering Inspection
 Wheel rotates easily and uniformly
 Fluid level in reservoir O.K.
 Proper pressure reading
 No leaks in system
 No unusual pump noise.
 Connections at rudder post tight

YES	NO	CORRECTED

Electrical System Check

- All 110 V systems work w/shorepower
- All 110 V systems work w/generator
- All 12 V systems operate properly
- All light bulbs O.K.

Fresh Water System Check

- Cold water runs freely from all faucets
- Hot water runs freely from all faucets
- Hand pump operation
- Showers operate properly
- Electric pump shuts off w/faucets closed
- Plumbing system free of leaks

Marine Toilets and Waste Lines

- Marine toilets operate properly
- Marine toilets free of leaks
- LectraSan units operational
- Sinks drain properly and no leaks
- Ice box drains function properly
- Cockpit drains function properly

Bilge Pumps

- Electric bilge pump operates in manual setting
- Electric bilge pump operates in automatic setting
- Manual bilge pump operates properly

YES	NO	CORRECTED

Other Systems & Equipment

- Refrigeration system(s) operate properly
- Air conditioning systems operate properly
- Electric windlass operates properly
- Stove operates properly
- Shaft brake operates properly
- Engine room blower operates properly
- All dealer or owner installed electronics
operates properly
- Emergency tiller operates properly
- All deck mounted winches operates properly
- Anchor roller rotates smoothly and shaft
Properly secured
- All deck blocks rotate smoothly
- All portlights and hatches operate correctly.
Port screen present

Check Joinerwork

- All drawers pull smoothly and latch in
closed position
- All doors open smoothly and latch in
closed position
- Sole drop-ins fit properly
- Berth access panels fit properly

Water Test Deck

- All fasteners tight
- Portlights free of leaks
- Portlights drains function properly
- Hatches free of leaks
- Toe rail free of leaks
- Other deck hardware free of leaks
- Cockpit drains operate properly

YES	NO	CORRECTED

All Coast Guard Required Safety Gear Aboard

Registration Numbers Mounted (If Applicable)

Sea Trial

- Engine, engine controls, engine instruments,
and drive train operate properly
- Steering system operates properly
- All sail handling gear operates properly
- All sails O.K.
- Shaft lock operates properly
- No excessive weather or lee helm
- Mast tuned under sail
- Compass swung
- All electronics operate properly
- Notes of weather & sea conditions

YES	NO	CORRECTED

Comments: _____

Commissioning and Decommissioning (cont.)

Name of Company and Individuals Involved

Owner Present

Commissioned by: _____

Sea Trials by: _____

Compass swung by: _____

Perkins start-up by: _____

Electronics checked by: _____

Yes

No

_____	_____
_____	_____
_____	_____
_____	_____
_____	_____
_____	_____
_____	_____
_____	_____
_____	_____
_____	_____
_____	_____
_____	_____
_____	_____
_____	_____
_____	_____
_____	_____
_____	_____
_____	_____
_____	_____
_____	_____
_____	_____
_____	_____
_____	_____
_____	_____

B. Decommissioning for Storage (Winterizing):

Winterizing consists of removing gear and equipment that may be damaged, removing liquids which may freeze, thorough cleaning of the yacht, and protecting the yacht from the elements. Procedures for winterizing are described below:

1. Drainage of fresh water system -

- a. Open faucets and run pump until water flow stops.
- b. Disconnect hoses at pump and use air pressure to blow out water in low spots.
- c. Remove drain plug on bottom fitting of water heater.
- d. Pump hand pump until water flow stops.
- e. Leave all faucet valves in open position.

Note: Non-toxic antifreeze for fresh water systems is available from many marine supply stores. This is recommended, since it will protect the system from any accumulations of water that were missed in the draining operations. Follow the instructions on the can. We understand that some owners have used Vodka for the same purpose - with favorable results.

2. Heads and holding tanks -

- a. Winterize heads by following the procedure given in the Raritan manual.
- b. Empty holding tank and rinse with fresh water and pump out again.

3. Thru-hulls -

- a. For in-water storage, all thru-hull valves, except cockpit scupper valves, should be closed.
- b. For out-of-water storage, leave valves open.

4. Engine -

- a. Engine coolant. Two acceptable methods of winterizing the engine cooling system are described below. Your Out Island 41 was winterized at the plat prior to shipping, using the second, and preferred method, adding anti-freeze to the system.

- (1) Complete drainage - Involves closing thru-hulls, removing all drain plugs on the engine and muffler, and opening drain petcocks per manufacturer's instructions. Store with expansion tank cap off and salt water pump cover loose.
 - (2) Anti-freeze - Drain system per instructions above. Close petcocks and replace drain plugs. Disconnect intake side of raw water pump horn and feed it into a bucket of pre-mixed antifreeze solution. Run engine until antifreeze is discharged from the exhaust, and then shut the engine off. Finally, fill the fresh water cooling system with antifreeze mixture.
- b. Drain and clean engine seawater strainer and leave top loose.
 - c. Check water separators in fuel system for water accumulation. Drain as needed.
 - d. Check engine handbook for further "lay-up" details.

Failure to adhere to the manual can affect your engine warranty.

5. Clean yacht interior -

- a. Clean and drain bilges.
- b. Remove all perishables.
- c. Wash out and dry refrigerators and/or ice boxes. Leave lids off and/or doors open.
- d. Empty all compartments, drawers, and hanging lockers. Clean and leave compartments open.
- e. Clean all interior surfaces.
- f. Clean and apply spray lubricant to steering units, engine coupling, hose clamps, rudder packing gland, shaft log packing gland, intermediate bearing, gate valves, and throttle/shift controls.

6. Remove the following gear -

- a. Electronics. Store at home or send out for any professional attention that may be required.
- b. Compass
- c. Cushions, seat backs, carpet, curtains, towels, etc. Store in dry area to prevent mildew.
- d. Interior light bulbs. Spray sockets and bases with WD-40 or CRC 6-66 to prevent corrosion.

- e. Batteries. Store in a warm, dry location. Check condition periodically and slow charge as required.
 - f. Sails. Wash and let dry thoroughly. Store in a dry area.
7. Drain shower pan pumps and strainers.
 8. Wash exterior. Polish, wash, and lubricate metal deck hardware.
 9. Wash and wax spars. Lubricate winches and sheaves. Inspect for any damage.
 10. Clean standing rigging and inspect for damage.
 11. Review manuals for all optional equipment. Follow any winterization procedures given. Generators, air conditioning systems, and some refrigeration systems are among those systems which require winterization.
 12. If boat is hauled, clean and inspect bottom thoroughly. Pay particular attention to signs of structural damage to glass, rudder operation, gudgeon weldment and fasteners, electronic senders, thru-hulls, propeller, and zincs.

Caution: Be certain that the Prop Shaft coupling is disconnected prior to hauling the yacht, and follow hauling instructions in this manual.
 13. It is a good practice to record items that were given attention and any defects found during decommissioning. This list will be valuable to you when re-commissioning in the Spring.
 14. Check owner's manuals for any optional equipment present on the yacht for specific instructions on winterization.
 15. You may wish to use deck covers and/or various devices available to prevent ice formation around a yacht stored in the water. These will provide additional protection to the yacht during the winter months. Consult your local marina for further information and sources of this equipment.

C. Recommissioning After Lay-Up:

Recommissioning after lay-up is somewhat less involved than the initial commissioning. The following steps are suggested:

1. Check operation of all thru-hulls before launching boat.
2. Apply anti-foulant bottom paint. Add zincs, if required.
3. Clean exterior of boat thoroughly.
4. Re-install charged batteries, checking terminals for correct polarity.
5. Check notes on decommissioning. Make any necessary repairs.
6. Launch, step spars, connect rigging, and tune mast. Bend on sails. Check all components prior to reinstalling them.
7. Reconnect coupling and check engine alignment.
8. If engine was drained, replace all drain plugs, tighten caps, and shut drain cocks. Fill and bleed engine cooling system.
9. Fill fuel tank. Bleed engine fuel system per instructions in the Perkin's engine manual.
10. Replace hot water heater plug and reconnect water line at pump. Flush the fresh water system, then fill the water tanks.
11. Clean and inspect engine and engine room equipment. Check oil levels throughout.
12. Clean interior thoroughly.
13. Check operation of all systems.
14. Install cushions, carpet, electronics, and other loose gear removed during winterization.
15. Sea Trial.

The check list provided in Section III-A will be a useful reference for the yacht's condition after recommissioning

D. Hauling and Cradling:

Improper hauling or cradling procedures can result in serious damage to the yacht. The following guidelines should be followed:

1. Prior to hauling, disconnect prop shaft coupling.
2. Refer to drawing number p located in the last section for proper placement of slings. Proper locations are also indicated by molded-in sling marks just under the hull sheer.
3. To prevent abrasion damage, the hull topside may be protected by placing carpet between the sling and the gelcoat. Be sure the carpet backing surface is against the sling.
4. If spars are removed, be certain they are properly supported for prolonged storage.
5. The hull should be cradled so that most of the weight is borne by the bottom of the keel. Side supports should contact the hull at or near a major bulkhead location.

IV. OPERATING PROCEDURES

A. Tips on Sailing the Out Island 41:

A discussion of general boat handling and sailing techniques is beyond the scope of this manual. This section describes the sailing characteristics of the Out Island 41 and presents several tips to how to achieve maximum performance from your yacht.

All yachts are a compromise. As such, each design has its strengths and weaknesses; the Out Island 41 is no exception. She is very beamy to allow for more living space below and more room to enjoy the pleasures of being on deck. In addition, her draft was kept relatively shallow so as to allow her owners to enjoy many anchorages and gunk holes. These can be enjoyed only by dinghy when sailing deeper draft yachts. As a beamy, shallow draft yacht, she must be handled on some points of sail in a slightly different way than a deeper draft yacht with less beam. The most prominent distinction exists on the wind and close reaching. Sail trim on both these points of sail is critical for optimum performance.

First, do not sail the yacht with any greater than a 25° angle of heel. Since she is a shallow draft boat, it is important that the keel stay as deep in the water as possible so as to minimize leeway. Install an inclinometer so you won't have any doubts concerning your heel angle. As the winds pipe up, shorten sail; keep the keel under the beat instead of alongside it, and she will surprise you with her abilities to windward.

Second, don't over trim the jib. In fact, don't over trim any sail, but especially the jib. The roller furling 150% genoa reacher found on most Out island 41's should not be trimmed any closer than a foot off the shrouds and usually not that close. Trimming the jib closer greatly reduces the speed of the beat. And, instead of making her point higher, this results in reducing considerably her distance made good to windward.

Third, the lead position is important on the jib and should be set such that the sail luffs in the top 1/3 of the luff just slightly before the other 2/3. To aid in determining the correct lead position, install three sets of yarns or tell tales on the jib about one foot back from the luff and evenly spaced up the soil.

These will also help you to achieve proper trim on most all points of sail. With the aid of the tell-tales, you can easily find the proper lead. Trim the jib about 1-1/2 feet from the shrouds, and steer the boat up until all ribbons inside and outside are laying nicely back along the luff. Now ease her closer to the wind and see which windward (inside) tell-tales begin to flutter first.

If those lower go first, move the lead back -- if those above are first, move it forward. Once the lead is set, mark the track so that if the snatch block gets moved, it is simple to put it back in the right place. As you come off the wind, toward beam reach, you will find that the upper tell-tales begin luffing even sooner. If you are fussy about trim, you could move the lead forward about six inches and call this a reaching lead. You could go to the forward lead when the apparent wind is further aft than 65°.

If your boat is equipped with Schaefer roller furling gear, you will note a significant sag in the luff of the sail when you sail to windward in 8 knots or better of true wind. This sag can only be minimized and can't be eliminated unless you go to a different furling system which uses the head stay. In adjusting the tension on the jib halyard for a Schaefer system, don't tighten it until the tension is taken off the headstay. However, you can tighten it almost to that point. The sag does reduce the boat's ability to point, however, not by as much as many believe. The sail is cut to accommodate the sag and hence to minimize the negative effect.

The alternative grooved headstay systems which can be installed instead of the Schaefer have the advantage that the headstay reduces the luff sag and improves windward performance of the yacht. However, it has one drawback. In order to change sails, the jib must be unfurled and lowered out of its groove to the deck. This process is quite difficult unless two people are available to handle the sail. One person must be at the mast lowering the halyard and helping bring in the sail; another must be at the headstay to pull the sail out of its groove. If the wind has freshened, and you are attempting to shorten sail; you will find that the stronger breeze also tries to blow the sail overboard since it isn't attached to the headstay after it is lowered. The Schaefer system allows for shortening sail simply by furling the jib, lowering the furled sail on deck, and hoisting the other jib. It is also possible to hoist another jib with the furled sail still in position simply by pulling the sheets forward and down as they won't interfere with the new sail. Note again the trade-off between the different systems.

When on the wind, the mainsail should be let out until a slight luff appears about 2 feet in back of the mast. It won't hurt the yacht's performance if it is sailed that way. In fact, if you own a ketch, the main should always luff slightly when on the wind. This will allow the mizzen to become an effective airfoil, because it won't be backwinded by the main.

Because the OI-41 is intended to be an easy to handle cruising yacht, the mainsail is sheeted at the after end of the boom. This is so no deck or cockpit space is lost to accommodate mid-boom sheeting or a traveler. As a result, when the yacht is on a reach, the main boom tends to rise and allows the leech of the sail to spill a good bit of wind

For those who are concerned by these small inefficiencies, a boom vang is the answer. Since the toe rail is holed throughout, it provides a random number of locations to tack the boom vang. When reaching, fasten the vang about two feet forward of the boom when the sail is in trim. Locate the claw or strap over the tack. Tension the vang until the main leech has only a slight camber. Now, let the sail out until a slight luff appears. This sail trim will produce optimum yacht performance.

If you own a sloop, slightly better windward performance can be attained by vanging the boom to windward from the end of the boom until it is on center line. Doing the same for a ketch will only backwind the mizzen and will not help the windward ability.

When sailing off the wind, the ordinary principles of sail trim prevail; ease the sail out until you get a little luff and then firm it up. Remember, always trim sail from forward to aft. That is, trim the jib first, then the main, then finally the mizzen.

As on any sailing yacht, halyard tension should be regulated so as to correctly position the draft of maximum camber of a sail. Tighter halyard tension moves the maximum draft forward, while looser halyards produce draft further aft. Halyard tension on Schaefer roller furling gear does not appreciably affect the draft, only the tension on the luff. However, for grooved stays, tension should be adjusted so that the maximum draft appears between $1/3$ and $1/2$ the distance back on the sail maximum draft on mainsails and mizzens should be 50% of the way back or approximately in the middle of the sail.

Your OI-41 should tack through $90-95^\circ$ on the compass in breezes above 10 knots and through $95-105^\circ$ in lighter winds. It is important to "sail the boat" through a tack so as not to stall her momentum. That means turn the wheel with moderate speed and break the old sheet just after the bow of the boat passes through the eye of the wind. Releasing the sheet sooner increases the chance of ending up in irons, while holding it longer means the boat will tend to stop as the jib backwinds.

When tacking from a reach to a reach, trim the jib in to a close hauled position before flipping. This helps the boat maintain forward speed while she goes through the wider tacking angle. Coordination between the helmsman and the sail trimmer is important to begin so that the optimum tacking speed can be learned. If you find your boat unusually difficult to tack, be sure you are following the above suggestions.

For cruising yachts without spinnakers, sailing downwind calls for a whisker pole. When sailing with the apparent wind between 150-180° on either tack, it is best to sail wing and wing. Pole the jib out to windward and keep the main to leeward. The jib will fill well up to 150°, and the whisker pole should be trimmed perpendicular to the apparent wind. On a ketch you can alternate jib, main, and mizzen on opposite sides of the boat to reduce the problem of back-winding. Be sure to put a preventer on the main boom, so you won't lose anyone in case of an accidental jibe.

When executing a jibe, it is always best to bring the main boom near mid-ships before the jibe then let it out after the stern passes through the wind. This reduces the hazards of a jibe and prevents the beam from riding up and hitting the back stay resulting in a goose-wing jibe.

Remember, all yachts incorporate compromises. The 0I-41 will not go to windward like a 12 meter. Neither would you have any desire to go cruising on a 12 meter. However, once you learn the few principles necessary to get optimum sailing performance from your yacht, you will have attained the best of both worlds.

B. Spars and Rigging:

1. Stepping the Mast and Dockside Tuning -

Assembling the rigging and stepping the mast are normally part of the commissioning procedures. The following steps should be followed:

- a. Check all rigging diagrams in this manual for proper attachment of the rigging to the mast. Rigging changes are much easier to effect on the ground than on a boson's chair at the masthead.
- b. Record lengths of each piece of standing rigging in the appropriate section of the commissioning check list (in the preceding section). In the first column, record the length shown on the Morgan tag attached to the piece of rigging. This is the correct design length. In the second column, record the actual measured length. Both numbers should agree to within 1/2". If a greater discrepancy is found, notify the factory.

Actual measurements should include the end fittings and the turnbuckle. The turnbuckles should be z,3's extended during the measurement (They are pinned in this position at the factory.) The measurement is taken from the centerlines of the pin holes (used to attach the piece of rigging to the mast) and the chainplates (extreme end pin holes).

- c. Install spreaders, standing rigging, and halyards to the spar. Install any required electronics wiring in the PVC mast conduit provided. Check all attachments and test lights and electronics wiring for proper functioning. Check that the mast step(s) is ready to accept the mast(s).
- d. Schedule the crane and suitable manpower to manually guide the mast(s) during stepping.
- e. Remove cotter pins from turnbuckles and extend to their full open position. Raise the mast to the vertical position and lower slowly into the deck partner. Guide electrical mast wiring through the hole carefully to prevent damage. Place the neoprene mast partner around the spar and work into place inside the aluminum collar as the mast is lowered in place.

Spray lubricant and a rubber mallet will help. Be sure wiring is held away from the step when lowering the mast onto the step.

- f. Attach the headstay first and then the backstay(s). Next connect the main shrouds and tighten turnbuckles by hand release crane support to the spar.
- g. Tighten backstay(s) until about a 2" deflection is visible when side pressure is applied approximately four feet above deck. Tighten main shrouds so that they are equally engaged and tension will allow approximately one inch deflection with a side load applied about four feet above deck level.
- h. Connect lower shrouds and tension equally for approximately two-inch deflection. Sight up the mast to determine the straightness of the mast. If any bends are visible, adjust lower shrouds accordingly until mast is reasonably straight. Intermediate uppers, if any, should be tightened to 1-1/2 inch deflection.
- i. Install cotterpins, bend over, and tape with rigging tape. Be sure spreader angle bisects shroud angle, then seize the spreaders and install spreader boots or tape ends. Install mast boot. Install boom and connect topping lift. Bend on sails and furl.

2. Tuning Under Sail -

With a 10 to 12 knot breeze, sail your yacht to weather. Sight the mainsail tracks for visual straightness. If the mast appears to take on an "S" curve laterally, luff up and adjust the weather shrouds accordingly. It will usually take only three or four turns on any single turnbuckle. Go back on the same tack and sight the track. If straight, change tacks and repeat the same procedure.

Adjust the fore and aft lowers to remove any bends in the longitudinal direction. The mast should be straight fore and aft, or have a very slight hook forward near the masthead. You may also notice the masthead falling off to leeward slightly, which is acceptable.

Check the final tuning by tacking several times until satisfied.

In moderate to heavy weather, a noticeably visible slack should appear in the leeward main shrouds. The lower shrouds to leeward should not be loose enough to flop around, but should have a feel of reduced applied load.

You may find it necessary to re-tune during the first fifty hours of sail. During this period, the shrouds may stretch slightly and the chainplates will take their final position.

Your Out Island has a fixed headstay length which has been determined by experience to provide the correct balance. If you experience lee helm or excessive weather helm, this can usually be corrected by changing the rake of the mast. Before changing the rake, be sure the actual setting matches the rake shown on the sailplan. Rake is changed by moving the mast step fore and aft. For excessive weather helm, the mast step is moved aft to decrease the aft rake of the mast. To correct lee helm, the step is moved forward to increase the aft rake of the mast. It is necessary to re-tune the rigging after changing the mast rake.

3. Halyards and Outhauls -

The halyards are located on the mast and are used to raise and tension the sail in the vertical direction. When the sail is fully up, there should be three to five wraps of wire around the halyard winch, and the rope tail should be used on the cleat.

The outhaul is located on the boom and is used for sail foot tensioning. It can be thought of as the horizontal halyard of the sail.

The clew of the sail is attached to the outhaul car which travels on a track. The car is controlled via a multi-purchase rope assembly (internal) that leads out to a cam cleat on the port side of the boom.

If a greater air pocket is desired for prevailing air conditions, the tension on the clew of the sail can be reduced by releasing the outhaul rope. This will allow the sail and outhaul car to travel forward on the track.

If prevailing air conditions required a flatter sail, tension is added to the clew outhaul rope, pulling car and sail toward the aft end of the boom.

Amount of adjustment required for each condition of sail is at the skipper's discretion.

It is recommended that when the yacht is at anchor, the clew outhaul tension be released to avoid stretching the sail.

4. Quick Reefing –

The following operating procedure is simply a suggested method of quick reefing with actual practice left to each individual skipper's discretion.

Reefing points are provided on the mainsail with reefing lines, blocks, etc. If your mainsail does not have lace lines, they should be added.

It is suggested that the aft end of boom (sail clew) be reefed first, then the tack. The reef line on the boom should be uncleated, and tension added to line via the winch to raise boom to reef point. The reefing line should then be re-cleated.

The halyard should now be eased, and the reef line on the mast uncleated, and pulled down, bringing the sail down to the boom gooseneck, leveling the boom. The halyard should be re-secured, the reef line re-cleated. The sail should now be laid on the boom, and the lace lines tied around the boom. The sail should now be neatly reefed to the boom.

If your sail has double reefing, the procedure should be the same as that above.

C. Engine:

1. Pre-Starting Check Off -

It is advisable to use a pre-start check list, as even the most experienced skipper can overlook an important detail that may evolve into an unpleasant or costly mishap. The check list will vary, as each owner may have optional equipment that will require attention at this time.

The following procedures are offered to help you develop your check list:

- a. Check fuel level.
- b. Open fuel shut-off valve.
- c. Check engine oil and transmission.
- d. Check for signs of fuel or oil leakage.
- e. Check engine coolant level.
- f. Open sea water intake to engine (gate valve).
- g. Check bilge, shaft log area.
- h. Check battery switch "on".
- i. Turn on "blower".

2. Starting Procedures -

- a. Release shaft lock, if so equipped.
- b. Set controls in neutral. Pull throttle control knob "out", if so equipped.
- c. Check operation of "stop" control.
- d. Advance throttle slightly - approx. 1/4.
- a. Turn ignition switch to "on" and operate "starter".
Note: Some engines equipped with "pre-heat". Check engine manual for instructions.
- f. Operate engine about 1000 rpm. Check immediately for oil pressure reading.
- g. Check for water discharge.
- h. Check ammeter for "charge" indication.
- i. Allow engine to reach normal operating temperature and observe any tendency to continue to rise.
- j. A final visual check of the engine room is recommended, as the engine is warming up.

- k. Check forward and reverse operation at idle speed before "casting off" lines.
3. Engine Operation -
 - a. Run engine at speeds as recommended in engine manual. Always reduce engine rpm to "idle" before shifting, and make throttle adjustments gradually.
 - b. Observe engine instruments periodically
 - c. Avoid long periods of maximum rpm, as well as extended "idle" periods. Always run engine long enough to reach normal operating temperature, as short runs cause excess engine deposits and sludge formation of oil.
 - d. Become familiar with the sound of your engine at its cruising speeds, and note any vibration characteristics. When an abnormal sound or vibration occurs, reduce rpm and make a quick check of instruments and conditions. Have problem checked as soon as possible.
 - e. Observe ammeter readings periodically; and as battery becomes charged (low charge rate), you may switch over to the #2 battery.
Caution: Do not turn battery switch to "off" position while engine is running. To do so will damage voltage regulators and possibly destroy diode rectifier in the alternator. It is advisable to reduce rpm to idle if possible, while switching batteries to prevent unnecessary surge on the system.

The alternator should not be charging at maximum for long periods of time, any more than an engine should. If this occurs, it is advisable to allow a cooling off period at 10 minute intervals, switching to the "charged" battery or operating at lower rpm's.

4. Engine Shutdown -
 - a. Allow the engine to idle for a few minutes before stopping and check instruments for proper readings.
 - b. Pull "stop" control and hold until engine stops. Return to "run" position.
 - c. Turn "off" ignition switch and blower.
 - d. Close fuel valve and seacock if boat is to be left unattended.
 - e. Visually check engine room and bilges for leakage.

NOTE: Check engine "hours" for maintenance scheduling (see engine manual).
READ AND USE YOUR ENGINE MANUAL.

D. Fuel System:

The standard fuel tank on your Out Island 41 is of welded aluminum construction, mounted in the engine room on the starboard side. The fuel shutoff valve is now operated by remote push-pull cables. The knob is located in the starboard locker in the cockpit. The knob is labeled "Fuel shut-off". Pull for off.

A bulkhead mounted fuel filter-water separator is provided in line between the engine and tank. Check periodically for water accumulation at this point by removing bottom plug and draining into a container. Replace the element at least once each season or as required by manufacturer's recommendations. There is also a final fuel filter on the engine itself which should be changed at intervals specified in your engine manual. The quantity of fuel in the tanks can be gauged by the use of a dip stick through the deckfill plate. Due to the contoured shape of the fuel tank, it is difficult to acquire a reliable electric gauge. The dip stick, though slightly inconvenient, is still the most accurate and reliable method to use.

The fuel tank and fill-deck plate are electrically bonded to the main ground at the engine. Although diesel fuel is considered relatively safe, safe fueling practices are always recommended:

1. Turn off hearers and galley equipment.
2. Extinguish all cigarettes, pipes, etc.
3. Stop engine and turn battery switch to "off".
4. Close all hatches and ports to prevent entry of fumes.
5. Do not attempt to take on fuel in rough water or inclement weather, as water might enter through the deck plate.
6. Avoid fueling after dark or in poorly lighted areas.
7. Maintain continuous contact between the nozzle and the deck plate fitting to eliminate the possibility of static electric discharge while filling.
8. Take on only gallonage anticipated by dip stick reading. Do not overfill to point where fuel remains in fill hose.
9. Wipe up or wash down spills after replacing and tightening deck plate cap.
10. Open all hatches, air bilges, and operate blower before starting engine or relighting galley stove. Turn batteries "on".
11. See engine manual for "bleeding" procedures.

Another note worth mentioning is to acquire your fuel from a reliable source. A diesel engine requires clean fuel; water and dirt being its worst enemy. Keep a clean and tight fuel system, and you will have a most reliable engine.

E. Electrical System:

It is important to remember that the D.C. electrical system in a boat is not the unlimited source of power that one is accustomed to in the home. The battery is a rechargeable storage cell. You can only take out of it what you have put into it, for a limited period of time. There is generally an over-abundance of electrical equipment drawing from the battery, and it is not intended to supply all these fixtures at one time.

1. Batteries –

The battery requires periodic attention to terminal connections, electrolyte level, and secure fastening. The use of a hydrometer is an inexpensive and accurate measure of the battery's condition. Specific gravity measurements of the electrolyte should read between 1.275 and 1.280 on a normally "charged" battery. All cells should read relatively equal; any one cell that has a noticeably low reading is an indication of a bad cell, and the battery should be replaced. The electrolyte (acid) level should be maintained to cover the plates in the battery. Add distilled water as necessary to maintain that level. Excessive need of water is an indication that the charging rate is too high. A check of the charging voltage should not read over 15.5 volts.

Exercise care in using an hydrometer, as well as all operations around the battery, due to the corrosive nature of sulfuric acid. It is a good practice to have a solution of baking soda around to clean up spills or drippings before they can do damage. Flush with fresh water. Baking soda is excellent for cleaning around batteries, provided the solution is not allowed to get into the cells. After cleaning the battery post and cable connections, a light coat of grease, Permatex, or special spray paint is an effective means of controlling further corrosion.

2. Alternator -

The next most critical point in the electrical system is the alternator. Its job is to maintain the battery's charge and cover the demands on the electrical system while the engine is running. The alternator converts mechanical energy into electrical energy, and the drive belt is its only link. This is normally the only periodic attention the alternator will need, maintenance-wise. With the engine stopped, the drive pulley on the alternator should

not be able to be turned by hand. Belt tension may seem tight enough, but the pulley may still slip if the belt is glazed or oily. When checking or tightening the alternator and its connections, it is advisable to turn off the battery switch. This prevents accidental "shorting" of the output terminal which is "live" even when the engine is at rest.

3. Starter -

The engine starter motor is the most demanding load that will be placed on the electrical system and is not fused or protected by an overload device. Therefore, it is wise to make periodic checks on the connections at the starter and solenoid switch for tightness and cleanliness. Do not allow tools or other metal objects to come into contact with these connections while the battery is "on",

4. Battery Switch –

The main battery switch connects either or both batteries to the engine circuit and the D.C. switch panel, which serves the boat's interior circuits. Do not switch to off position with engine running. "Both" position is intended for emergency or extended engine cranking ability. Continuous running in the "both" position when the batteries are in a low state of charge, can cause overload and possible damage to the engine alternator.

5. Electrical Panel -

The AC-DC breaker panel is located in the walk-thru area of the forward companionway. This panel is equipped with quality hydraulic-magnetic circuit breakers.

Each circuit breaker is wired to an indicator light to show at a glance if the circuit is on. The D.C. indicator lights are solid state light-emitting diodes which require very little current draw. The A.C. indicator lights are neon, and each of the A.C. breakers are of the double pole type which breaks both sides of the circuit when tripped.

The D.C. ammeter monitors the amount of current drawn from the battery, and the voltmeter gives an indication of the battery 's condition.

The voltage reading may be interpreted as follows:

		<u>Battery Condition</u>
Engine off and electrical system under minimal or no load	below 11 volts	Very Low
	11-12 volts	Low
	12-13 volts	Well charged
Engine running fast idle or above	13-13.5 volts	Low charge rate
	13.5-15.5 volts	Normal charge
	15.5 or higher	Excessive voltage (Voltage regulator defective. Replace or adjust.)

The voltage readings should be taken in either battery position, not in "both". Start your engine on the highest charge battery and allow time for the battery to return to its full charge state before putting it on reserve. When switching over to the other battery, be sure not to switch through the "off" position. This would damage the regulator and possibly the alternator diodes. The "both" position is for emergency or extended cranking periods and should not be used to charge two batteries at the same time. This could overload the charging circuit if the batteries are low.

6. Pedestal Switches -

The navigation lights, foredeck light, and bilge pumps are controlled by switches on the pedestal.

The automatic bilge pump switch may be left in the "auto" position, and the pump will come on whenever there is sufficient water in the bilge to activate the float switch. At this time, an indicator light on the pedestal will show that the pump is "on". The "manual" position allows the pump to run continually, overriding the float switch, until the switch is returned to the center "off" position.

The switches on the fuse panel are connected to an enclosed fuse panel inside the pedestal. A chart inside the panel cover identifies the fuse, location, and size required.

Spare fuses should be kept on board for these circuits as listed on the next page:

Running Lights	10 amp	Bilge Pump	7.5 amp
Bow Light	2 amp	Blower	10 amp
Foredeck Light	7.5 amp	Inst. Lt.	7.5 amp
Masthead Light	2 amp	Compass	2 amp

7. A.C. 110 Volt Shore Power System -

The A.C. system is a three-wire shore-grounded circuit. The shore power inlet is rated at 30 amps and is mounted on the starboard side of the cockpit coaming.

The main circuit breaker is located in the engine room on the forward bulkhead adjacent to the engine room door. This, in turn, feeds the A.C. breaker panel. Each circuit (A.C.) is protected by a double pole breaker. There are two breakers provided for the two separate receptacle circuits. For reasons of safety, it is recommended that all appliances used aboard be equipped with a three-wire grounded cord.

The hot water heater is connected to a breaker on this panel, but also has a high temperature reset button built into the heater. Before applying power to the water heater, always be sure the heater has been filled by turning on one of the hot water faucets long enough to get a steady flow. An empty hot water heater will burn out the heating element before the temperature reset button can break the circuit.

The proper procedure for connecting shore power to the boat safely is as follows.

- a. Turn ship's main breaker to "off".
- b. Turn receptacle on dock to "off", if possible.
- c. Connect cable to power inlet on boat first (to prevent handling a "live" power line and possibly coming in contact with water).
- d. Route the cable in such a way as to prevent strain on either connector, allowing for the rise and fall of the tide, and to prevent chafing.
- e. Connect to dockside receptacle and turn shore switch on.
- f. Turn on ship's main breaker.

Disconnect Procedure:

- a. Turn off ship's main breaker.

- b. Turn off dockside power and disconnect cord.
- c. Replace all weather-tight caps on receptacles.

The owner must be aware of the hazards of using high voltage AC aboard ship and should maintain this system in safe condition.

Don't take chances handling A.C. equipment in wet weather or while washing down topsides. Caution guests and children about hazards, and do not turn any equipment that does not function properly or is suspected of being defective.

8. Battery Charger Option -

The battery charger, or converter, as it is also referred to, is connected to the feed or "output" side of the main battery switch. This allows you to select either or both batteries to be put "on the line" for charging when the engine is at rest. It also insures that, when the battery switch is "off", all circuits are positively disconnected from the batteries during an emergency shutdown.

Do not turn the battery charger on when the battery switch is in the "off" position. This could possibly feed the ship's circuits without the back-up support of the batteries. It could also cause premature failure of electrical equipment in the boat, if the regulator section of the charger should fail, allowing high voltage into the system.

The battery charger has an automatic cut-off circuit which is wired to the engine electrical system. Whenever the engine is started, the charger will shut off and allow the engine driven alternator to take over, returning to service when the engine is stopped.

The charger is protected by internally-mounted fuses on the AC and DC circuits, as well as the main circuit breaker on the AC panel. Be sure all the related circuits are "off" when opening the charger cabinet for service. The charger is an air-cooled unit with louvers on top and bottom. Care must be taken not to restrict the ventilation provided, nor allow small tools or hardware to fall into the charger while performing maintenance work in the engine room.

9. A.C. Generator Option -

The A.C. generator option presently being installed is an Onan 7.5 KW diesel powered unit. It is advisable to read owner's manual provided with the unit and become familiar with the check points and operation before starting this unit for the first time.

Normal start up checks should include the following steps:

- a. Check oil and water.
- b. Open sea water cooling gate valve.
- c. Open exhaust thru hull gate valve.
- d. Check main generator circuit breaker(s) "on".
- e. Check fuel shut off valve at tank for "on"

Generator Starting:

- a. Hold pre-heat switch on for 15 seconds.
- b. Hold start switch on until unit begins to run. Starter will automatically disengage when engine reaches running speed.
- c. Release both switches.
- d. Turn ship-shore power switch to "ship" position
- e. Observe A.C. voltage and frequency on meter panel, check for water discharge at generator exhaust port.
- f. A.C. power is now available at main panel.

NOTE: OPERATE ENGINE ROOM BLOWER, (IF NOT WIRED
AUTOMATIC)

The generator is protected with cut-off switches for high temperature and/or low oil pressure. Refer to your Onan manual for trouble shooting procedures, and to the wiring diagrams in your boat owner's manual.

The generator system has a separate fuel system from the tank to the unit, which includes an in-line fuel/water separator, fuel tank shut off, and pick up tube in the tank. The return line is connected to a tee fitting with the main propulsion engine's return line at the tank.

The sea water cooling system is also independent of the main system with its own gate valve and sea strainer.

Winterizing procedures will be found in the Onan owner's manual. The fresh water cooling system can be protected with an ethylene glycol type antifreeze and is recommended for all season use.

F. Plumbing System:

1. Thru-Hull Connections -

Below is a list of thru-hull penetrations and their connections. It is advisable to become familiar with the location and operation of each one, with the thought in mind to maintain quick access in the event of emergency.

Forward Head - access through cabinet door under sink.

Toilet intake - 3/4" gate valve

Toilet discharge - 1-1/4" gate valve

Sink and forward shower discharge - 1-1/4" gate valve

Galley - access through cabinet door under sink.

Galley sink drain - 1-1/4" gate valve

Engine Room:

Raw water intake to engine - 1-1/4" gate valve located aft on port side of engine, near door.

Aft cockpit drain and bilge pump - 1-1/4" gate valve located aft on port side of engine near door.

Forward cockpit drain, shower pump and aft head sink - 1-1/4" gate valve, located on starboard side of engine near aft bulkhead.

Aft head - access through cabinet door under sink.

Toilet intake - 3/4" gate valve

Toilet discharge - 1-1/4" gate valve

Note: It is a good practice to close all gate valves when leaving the boat unattended. The only exception is the cockpit drain thru-hulls which also serve the bilge pumps. This is not only intended as a safety factor, but also insures that gate valves are maintained in working condition, in the event it becomes necessary to close them in an emergency situation.

Prop Shaft - access through cabin sole drop-in panel in aft stateroom. See details on prop shaft stuffing box in "Maintenance Procedures" section.

Rudder Shaft - accessible through drop-in under aft berth.

Rudder Shaft Stuffing Box - see "Maintenance Procedures".

Engine Exhaust - not fitted with gate valve, access to thru-hull fitting is accessible under aft berth drop-in panel.

2. Fresh Water System -

An aluminum water tank, 132 gallon capacity, is located on the port side of the walk-thru area between the main cabin and the aft stateroom. An access door to inspect the fill and vent connections is located just above the tank in the walk-thru area. The main shut-off valve is located at the bottom forward corner of the tank and is accessible through the lower door at the navigator's station. The amount of water in the tank is measured by the use of a dip stick inserted through the deck fill plate. Do not use the fuel tank dip stick for this purpose. The water tank dip stick may be stored in the access compartment over the water tank.

A reserve 38-gallon water tank is located on the starboard side of the engine room, beneath the optional generator mount platform. This is connected to a pair of valves located under the galley sink to allow selection of either tank to feed the fresh water pump.

The pressure pump is located under the cabinet below the companionway ladder. A manually operated hand pump is installed at the galley sink for use under conditions of power or pump failure. This hand pump is connected to the electric pump inlet line with a tee connection and a gate valve, which is normally kept closed until such a need arises. The hand pump gate valve is located under the galley sink. There is an in-line strainer at the water pressure pump. This prevents foreign material from reaching the pump and should be checked periodically. Leaving manual pump gate valve open while operating pressure water system may cause air in the waterlines.

The pressure water pump is activated by a switch on the D.C. panel and will run until the water pressure reaches 30 psi. When a faucet is opened and pressure water drops, it will automatically re-start at 16 psi. Upon closing the faucet, the pump will again shut off at 30 psi. If the pump cycles on and off by itself, it is an indication of a leak in the system.

When filling the fresh water system for the first time or whenever the system has completely run out of water, it will be necessary to run the pressure pump long enough to purge the air from the lines. Starting with the faucet closest to the pump, run the hot water side until a solid stream of water flows. It is important that the hot water heater is bled in this manner before turning on the A.C. breaker, as the heating element will be damaged if the tank is empty.

Operate each faucet in turn until air is out of the system and "tap off" the water tank.

The hot water heater also utilizes the engine cooling system to heat water while the boat is underway. The connecting lines and the heat exchanger must be bled when the engine cooling system is filled.

3. Bilge Pumps -

The bilge pump is a submersible type pump capable of removing 1400 gallons per hour. It is actuated by a switch on the pedestal in either the automatic position (via the float switch) or in the manual position, which overrides the float switch. It will run continuously until returned to "off" or automatic. The water is routed to the aft cockpit drain in the engine room.

4. Sump Pump -

A sump pump is provided for each shower, one forward, and one aft. It is controlled by a switch in each head which must be turned on when using the shower. The circuit is protected by a 10 amp breaker on the D.C. panel.

5. Marine Heads -

The marine head is manually operated, using sea water for flushing. The inlet and discharge gate valves should be checked to be open before using.

A decal is supplied with operating instructions which should be mounted on the bulkhead adjacent to the toilet. Further detailed instructions for winterizing, etc., will be found in the manual supplied by the head manufacturer are:

"To Operate Toilet": "Inlet valve should be in open position. Before using, pump to wet inside of bowl. After using, pump until thoroughly cleaned. Pump a few more times to clean lines. If excess waste should cause water to rise in bowl, stop pumping until water recedes."

"To Winterize Toilet": "Shut off intake valve. Pump until dry. Remove drain plug in base. Pump again to remove all water. Do not use anti-freeze."

"Do not put rags, matches, paper towels, or anything in bowl that will plug up valves."

6. Holding Tanks -

Holding tanks, for use in restricted waters, allow the heads to be used as needed. But, one must remember to minimize the amount of water pumped for flushing to extend the capacity of the tank. The holding tank is a flexible rubber/nylon tank, installed in a compartment as near to the head as possible. This location may vary depending on the model of the boat and related options.

It is connected to a "tee" fitting in the normal overboard head discharge system. To use the holding tank, rather than the overboard discharge, the gate valve at the thru-hull must be closed first and then open the holding tank shut off valve.

The holding tank has a capacity of 15 gallons, enough for 30 average flushings. A deck plate provides for pumping out at dockside, and the system should be rinsed and re-pumped out. This can be done by pumping through the toilet or by a hose through the deck plate. Use of a commercial chemical toilet treatment and deodorizer is recommended.

Lectra/San: waste treatment system. This unit is an electrolytic chlorinator; and when used with a marine toilet, provides a flow thru treatment that has been accepted as meeting the Federal requirements (Federal Register Vol.41 - No.147).

A salt feed tank is used for operation in fresh or brackish waters, as the system is designed for use in salt water. This is done automatically, and details on the adjustment and service will be found in the Lectra/San Manual.

Operation of the unit is accomplished by:

1. Activate the "start" button
2. Pump the "flush" handle 6-10 strokes.

After the treatment cycle (about 2-1/2 mm.), the unit will shut down. Toilet is now ready for next use. NOTE: The toilet can be used during the treatment cycle; but, the flushing should not be done until the previous treatment cycle has been completed and the "operating" light off.

Maintenance and trouble shooting information will be found in the manual supplied with the unit, as well as winterizing procedures and re-commissioning.

Do not operate unit without water in the treatment unit, as serious damage can occur.

7. Optional Dockside Water Supply -

As an added convenience, a dockside water supply may be installed. This allows the boat's fresh water system to operate without drawing from the tank or using the ship's D.C. power supply to operate the pump.

The water inlet fitting is mounted on the starboard cockpit coaming near the shore power inlet and is connected by means of a garden hose to the shore supply.

In the engine room, on the forward bulkhead, is a pressure regulator valve which maintains 40 psi or less to the fresh water system.

The electric pressure pump has a check valve in the outlet fitting which prevents water from flowing back to the boat's water tank.

CAUTION: Do not leave the boat unattended with the pressure water line "on". A failure in any of the yacht's water lines could result in sinking of the yacht.

G. Refrigeration:

1. Ice Box-

The ice box is a one-piece molded fiberglass unit insulated with a nominal three-inch-thick surrounding of polyurethane foam. The inner surface is gel-coated with a sanitaryware formula which is non-toxic and will not "flavor" food.

The drain is connected directly to a hand pump located beneath the galley sink and is pumped overboard through a connection in the galley sink drain.

When the boat is to be idle for a prolonged period, it is advisable to flush the ice box and leave it open to the air to prevent mildew or odor formation.

2. Ice Maker Option (Icerette) -

The icemaker operates on 110 volt A.C. shore power and uses water from the boat's fresh water system. The fresh water pump breaker must be on, and the 110 volt circuits must also be operational. There is a separate breaker on the 414 model electric panel. On the 414 model, the icemaker is connected to the receptacle circuit.

The icemaker is connected to the water system through a shut-off valve located under the galley sink.

An "on-off" switch is located in the unit beneath the icemaker door.

It takes approximately 45 minutes for the unit to cycle when first started. During the initial start up it is advisable to discard the ice cubes made for the first two or three hours. This is due to the possibility that dirt and foreign matter may have entered during manufacture. Read the owner's manual for details on temperature adjustments and trouble shooting.

3. Norcold Refrigeration Option -

A dual voltage refrigerator may be optionally installed, which

operates on 110 volt shore power and automatically switches over to 12 volt D.C. when shore power is off.

The refrigerator is connected to the boat's "receptacle" circuit by a plug and wall outlet behind the refrigerator. The D.C. circuit is wired directly to the main D.C. panel.

The panel switch or breaker should be left in the "on" position, and the refrigeration controlled by the thermostat switch inside the cabinet. In the event of an A.C. failure when the boat is dockside and unattended, the unit will automatically switch over to the ship's power without any subsequent loss of cooling or spoiling of perishable food.

The owner's manual provided with the Norcold refrigerator gives detailed information on operation and trouble shooting. Particularly important is the notation to be sure that the unit is turned "off" when using a "quick charger". This could allow high voltage to damage the inverter.

Another item to consider is the thermostat setting which should be kept at a level just low enough to keep the unit cold. This will minimize the amount of running time, and thus conserve battery power.

4. Grunert Refrigerator -

Your "Hold Over" refrigeration system differs from conventional refrigeration in several ways. The evaporator plates are tanks which contain a mild anti-freeze solution. This solution freezes and melts at +26 degrees (40 degrees refrigeration) or 0 degrees (freezers) to provide a long cooling effect while not using A.C. power.

When the unit is first started, a long running cycle should be expected, as all the solution must freeze before the unit begins to cycle. Once frozen, however, the unit will cycle normally and provide conventional refrigeration while at dockside.

When cruising away from shore power, the system should be run twice a day from the generator. to be assured of the longest hold-over possible, the eutectic solution in the plates should be completely frozen. The unit should have cycled with the cold control at normal (#5) or colder before turning

off the unit at the thermostat.

On "spill over" systems with plates installed only in the freezer section, chilled air is supplied to the refrigerator section through automatic damper controls which are low on the refrigerator side of the dividing barrier. These can be adjusted for warmer or cooler temperatures in that section. The openings for these louvers through the divider should not be obstructed on either side of the barrier.

The finned condenser on the unit should be kept clean and, particularly on units that are air cooled only, must have adequate and free air circulation.

On units with auxiliary water cooling, the strainer should be checked regularly and cleaned periodically. The cooling water flow can be checked at the overboard fitting, which should be just above the water line. A spare set of pump impellers should be kept on hand.

Defrost evaporator or Sta-Cold plates when the frost or thickness exceeds 1/4". To defrost quickly, warm water or warm air from a heater or hair dryer may be used. when it is not desirable to completely warm up the refrigerated compartment, the plates may be scraped clear of frost with a plastic or wooden scraper.

When not operating the unit, open the cabinet doors or hatches to allow air circulation in the cabinet and to prevent mildew and odor.

A.C. sealed units do not require winter storage pump down. When securing the unit for a storage period, spraying the condensing unit lightly with CRC or a similar light oil is recommended. If the unit is subject to extremely damp conditions, use spray paint as required to prevent rust.

H. Optional Air Conditioning (Marinaire):

The air conditioning units are 110 volt operated and sea water cooled by remote mounted pumps. The units also contain a heating element for cold weather use.

A sea water inlet gate valve is located aft in the engine compartment and must be opened before using the air conditioner, or damage to the pump impeller will result. The pump is also protected by a sea strainer which is maintained and serviced the same as you would for your main engine. Cooling water is discharged on the starboard side behind the aft head at boot top level.

There are two discharge ports; the forward one serving the forward air conditioning. Pump operation may be checked by observing water discharge from these ports immediately after turning the control switch to "start" position. Allow unit to remain in the "start" position long enough to observe water flow. Switch to "run", at which time the compressor will start and cooling begins. The temperature is thermostatically controlled, and the fan speed is generally left on high until the desired temperature is reached. The fan may then be set to the desired level.

Condensation water that forms in the units is drained into the bilge.

To winterize units, disconnect the pump connector plug, and drain sea water lines (gate valve closed) and sea strainer. The units may be operated after winterizing in the "heat" position (temperature control turned counter clockwise).

Remember to reconnect plug and lines before using "cooling" when warm weather returns.

Detailed instructions for servicing and trouble shooting these units will be found in the Marinaire "Cabin Mate" Manual.

When the air conditioning option is requested on the OI-41 model, a second 30 amp shore power system is installed. The load is then divided between the two to prevent overloading of the boat's standard electrical system, as each unit is capable of drawing approx. 16 amps A.C.

I. Alcohol Stove:

Although a copy of the manufacturer's operating instructions is included in the owner's packet, we would like to bring some of the basic and important instructions to your attention:

I. Fueling -

Always purchase a good grade of de-natured Ethyl Alcohol for your stove. Ethyl Glycol or Methyl Alcohol are not recommended, as they cause operational failure and possible damage to the unit.

Unless a remote fill station is installed in your vessel, filling should be at the tank fill. Loosen fill cap slowly to relieve any pressure. Remove fill cap and fill tank with alcohol, using a funnel. Replace cap and screw in place.

2. Operating -

- a. Pump tank to 20 pounds air pressure,
- b. Preheat burners one at a time. Carefully open the burner control to allow alcohol to flow into the primary cup beneath the burner until the center section of the cup is about half full. Do not over-fill. Shut off burner control and light burner. A momentary flare up during initial ignition is normal. The purpose of pre-heating is to assure that the alcohol entering the flame is vaporized. Vaporized alcohol will ignite and control like a gas burner.
- c. Turn on the burner control. A flare up at this time indicates insufficient pre-heating. If this occurs, shut the burner control off, allow the burner to cool, and repeat steps b and c.
- d. Operate the burner as you would a gas stove. Flame intensity is controlled with the burner knob. Periodically, check the tank pressure. Proper burner performance requires a pressure of between 10 and 20 psi.

3 Shut Off -

To shut off stove, turn control knob to the right, cutting off the flow of alcohol to the burner.

Release air pressure at the storage tank by loosening filler cap to avoid "flooding" of burner, should controls be accidentally opened when stove is not in use. If a ball type shut-off valve is installed in the alcohol line near the stove and is used for fuel shut-off, the tank pressure need not be released except for filling operation.

4. Miscellaneous -

General information and maintenance tips are outlined in your manufacturer's instructions. Please read them carefully before using your stove. Though alcohol is a relatively safe cooking fuel and easily extinguished with water, a thorough understanding and familiarity of the equipment is the best safety device and precaution.

Good cooking to you in your practice of the seafaring culinary arts!

J. Opening Ports and Hatches:

1. Ports -

The opening ports on your Out Island 41 are all plastic. This eliminates the corrosion problems associated with metal frames. The glazing is Lexan, an extremely tough plastic, which flexes but is almost impossible to break. A neoprene "O" ring is the primary seal between the glazing and the frame.

When dogging down the ports, it is not necessary to use more than "finger tightening" force. Excessive force, for example, through the use of pliers, may damage the gasket. If finger tightening does not provide a complete seal, open the port and check the seating of the gasket. The usual causes for leaks through the port lights are shifted or damaged gaskets an/or dirt on the gasket or lens surface.

The portlights have integral sill drains. If water collects in the lower recesses, check that the drain holes are free.

2. Hatches -

The operation of the hatches is straightforward. The following precautions will prevent accidents and reduce the chance of damaging the hatches.

- Open and close hatches carefully. The thermoformed acrylic hatches can be damaged (at the hinge attachment) by slamming the hatch opened or closed.
- When the hatch is to be left open, be sure that all positioning devices are used.
- Before closing the hatches, be sure all obstructions (particularly fingers and heads) are clear.
- When dogging down the hatches, do not use excessive force. You should not need to use any tools for this purpose.

K. Navigation Lights:

Navigation, or "running" lights must be in accordance with the rules and regulations of the navigable water the yacht owner intends to use.

International rules and regulations are required to be observed on seagoing vessels. The Inland rules and regulations are for intracoastal waterways, with certain areas such as the Great Lakes and Western rivers having special requirements and rules pertinent to their local areas.

Morgan Yacht has listed the following notes, for your reference, from the international rules. We suggest the owner of any vessel acquire a copy of the United States Coast Guard publications on the "Rules of the Road" for their intended areas of navigation.

In general, the navigation lights are required from sunset to sunrise, weather conditions good or bad. It is suggested that, in times of reduced visibility, from sunrise to sunset, navigation lights be operational.

If vessel is underway by use of power, and is under 150 feet in length, is required to operate a forward light, white in color, 20 point angle (225 degrees), 5 miles visibility range; a stern light, white in color, 12 point angle (135 degrees), 2 mile visibility range; side lights, green to starboard, red to port, in color, 10 point angle (112-1/2 degrees), 2 mile visibility range.

If vessel is underway by use of sail, it is required to operate its side lights (same specification as underway power) and stern light.

If vessel is anchored, it is required to operate its anchor lights, white in color, 32 point angle (360 degrees), 2 mile visibility range.

The yachtsman is encouraged to become familiar with the complete rules and regulations of the above mentioned situations, as well as other possible conditions of operation. Proper operation and use of navigational lights is important for the safety of the yachtsman and the future of boating. A diagram illustrating navigation lights installed on your Out Island 41 at the factory is given in the last section of this manual.

IV. OPERATING PROCEDURES

L. Lightning Protection

Your yacht was not provided with a lightning protection system during construction at Morgan Yacht. The reasons are as follows:

1. We are not aware of a procedure for lightning protection which is proven reliable under all conditions. We are aware of situations where yachts with elaborate lightning protection systems have sustained serious damage from a direct lightning strike.
2. If the builder were to assert that the yacht were lightning protected, it could instill a false sense of confidence in the owner/operator, leading to less than prudent actions when lightning threatened.
3. Lightning systems are "out-of-sight, out-of-mind", except when lightning threatens. Generally, they are not checked and maintained on a regular basis. A defect in the system (i.e. a break in a ground line) could, in some cases, increase the risk of personal harm and damage to the yacht, as compared to a yacht with no protection. The reason for this is that many lightning protection systems distribute the high voltage throughout the yacht before allowing it to exit through the ground.
4. It is impossible for Morgan Yacht to control changes you, the owner, may make to the yacht, which could affect the lightning protection system.

You, the owner, must decide whether you wish to equip your yacht with lightning protection, and if so, the method of doing so. For your guidance, a copy of ABYC recommendations is attached. The following suggestions and comments are also offered:

1. Keep the system as simple as possible. This will facilitate both installation and inspection/maintenance. Perhaps a single oversize ground (battery cable) from the mast base to the engine, coupled with external shroud grounds (see 2 below), will maximize reliability.
2. ABYC recommends straight line wire runs, which is virtually impossible within the yacht. For grounding the shrouds, a battery cable, which clips to each shroud and extends outside the yacht to the water, can minimize the number of bends required. This method has the added advantages of keeping the power surge outside the boat and allowing easy and routine inspection. The obvious disadvantage is that the clip-on cables are not a permanent installation and may not be in place when an unexpected lightning strike occurs.
3. Use only top quality materials and go oversize where possible.

IV. OPERATING PROCEDURES

L. Lightning Protection (continued)

4. Keep all permanent attachment points and connections where they are readily available for inspection, yet protected from damage or inadvertent disconnection.

Factory installed metal tanks, 110 volt systems and major metal components are grounded to the engine. The engine is grounded via the shaft and prop to the water. The purpose of the internal grounding is for static charge control and accidental shorts in the internal systems -- not to provide lightning protection. However, you can incorporate the ground lines present in a lightning protection system you may wish to add.

By far the most important consideration regarding lightning is observing common sense safety precautions when lightning threatens. The key considerations are listed in paragraph 7 of the attached ABYC recommendations.

RECOMMENDED PRACTICES AND STANDARDS COVERING LIGHTNING PROTECTION

PROJECT E-4 (ADOPTED NOV.3, 1959)

ABYC E-4-70

1.0 *SCOPE*

- 1.01 WHEREIN standards and recommended practices outline the means whereby all types of craft can be afforded a high degree of protection against lightning.

2.0 *GENERAL PRINCIPLES*

- 2.01 In view of the wide variation in structural design of boats, the following basic guides should be considered and used in designing and installing a lightning protection system for any given craft: (See Fig.1.)

- 2.1 A grounded conductor, or lightning protective mast, will generally divert to itself direct hits which might otherwise fall within a cone-shaped space, the apex of which is the top of the conductor or lightning protective mast and the base is a circle at the surface of the water having a radius of approximately two times the height of the conductor. The probability of protection is considered to be 99.0 percent for the 60 degree angle shown in the illustration. The probability of protection can be increased to 99.9 percent by increasing the height of the mast so that the 60 degree angle becomes 45 degrees.

- 2.2 To provide an adequately grounded conductor or lightning protective mast, the entire circuit from the top of the mast to the ground should have a conduction equivalent to a No.8 A.W.G. copper conductor and the path to ground followed by the conductor should be effectively straight.

- 2.3 If there are metal objects of considerable size within a few feet of the grounding conductor, there will be a strong tendency for sparks or side flashes to jump from the grounding conductor to the metal object at the closest point. To prevent damage from such side flashes an interconnecting conductor should be provided at all places where they are likely to occur.

- 2.4 Large metallic objects within the hull or superstructure of a boat should be interconnected with the lightning protective system, or the bonding system, to prevent a dangerous rise of voltage due to a lightning flash. Items which are not part of the electrical system of the boat may be independently grounded, provided it is not practical to interconnect with the lightning protective or bonding systems.

- 2.5 Since a lightning conductor system is expected to remain in working condition for a long period of time with relatively little attention, the mechanical construction should be strong and the materials used should offer high resistance to corrosion.

3.0 *INSTALLATION RECOMMENDATIONS*

- 3.1 *Lightning Protective Mast:* - A lightning protective mast should be of adequate height (Section 2.1.) and should be mechanically strong in order to withstand exposure to use and weather. If the mast is of non-conducting material, the associated lightning or grounding conductor should be essentially straight, securely fastened to the mast, should extend at least 6 inches above the mast, should preferably terminate in a sharp point and should meet the requirements of Section 3.3.

- 3.2 *Radio Antenna* - A radio antenna may serve as a lightning protective mast provided it is equipped with transmitting type lightning arresters or means for grounding during electrical storms. The grounding of metal rod type radio antennas constitutes sufficient protection for wooden boats, without masts and spars, provided the following conditions are met:

- 3.21 All conductors in the grounding circuit of the antenna are at least No.8 A.W.G. copper or equivalent in accordance with Section 3.31.

- 3.22 A line drawn from the top of the antenna downward toward the water at an angle of 60° to the vertical does not intercept any part of the boat. (Section 2.1).
- 3.23 Antennas with loading coils are considered to end at a point immediately below the loading coil unless this coil is provided with a suitable gap for by-passing the lightning current.
- 3.24 Non-conducting antenna masts with spirally wrapped conductors are not considered suitable for lightning protection purposes.
- 3.3 *Materials* - The materials used in the making of a protective system should be resistant to corrosion. No combination of metals should be used that forms a galvanic couple of such a nature that in the presence of moisture or direct submersion, corrosion is accelerated. Except for the use of conducting materials which are otherwise part of the structure of the boat, only copper should be used as the conductor. Where copper is used, it should be of the grade ordinarily required for commercial electrical work, generally designated as being of 98 percent conductivity when annealed.

3.31 *Copper Conductor*

Copper conductor should weigh at least 50 lbs. per thousand feet.

Copper cable conductors should be of a diameter not less than No.8 A.W.G. The size of any wire of a cable should be not less than No.17 A.W.G. The thickness of any copper ribbon or strip should be not less than No.20 A.W.G. (0.032 inch).

Where other materials are used the gauge should be such as to give conductivity equal to or greater than No.8 A.W.G. copper cable

3.32 *Joints*

Joints should be mechanically strong and should be so made that they have an electrical resistance not in excess of that of 2 feet of conductor.

I

3.4 *Interconnect of Metallic Masses*

- 3.41 *Interconnection or Grounding* - Metallic masses aboard boats which are a permanent part of the boat, or are permanently installed within or about it, should with the exception of those of comparatively small size, be made a part of the lightning-conductor system by interconnection with it (see Paragraph 2.4.) or independently grounded, or both, depending upon their location with respect to the lightning conductors and their surroundings, as more fully described in Sections 3.42 to 3.44, inclusive.

Note: The object of interconnecting the metal parts of a boat with the conductor is to prevent damage from side flashes especially in the case of rather extensive metal objects that are near by. The main principle to be observed in the prevention of such damage is to pick out on a boat the place when side-flashes are most likely to occur and provide metallic paths for them

- 3.42 *Exterior Bodies of Metal* - Metal situated wholly on the exterior of boats should be electrically connected to the grounding conductor at its upper or its nearest end, and, if of considerable length, should be also grounded or electrically connected to the conductor at its lower or its farthest end.

Note: Exterior metal bodies on boats include any large masses such as horizon rail handrails on cabin tops, smoke stacks from galley stoves, davits or metal signal masts.

- 3.43 *Interior Bodies of Metal* - Metal situated wholly in the interior of boats which at any point comes within 6 feet of a lightning conductor should be electrically interconnected with it. The bonding required to prevent electrolysis should be considered adequate.

Note: Interior bodies of metal include engines, water and gasoline tanks, control rods for steering gear or reversing gear. It is not intended that small metal objects such as compasses, clocks, galley stoves, medicine chests, and other part of the boat's hardware should be grounded.

- 3.44 Metal which projects through cabin tops, decks or sides of boats above the sheer should be bonded to the nearest lightning conductor at the point where the metal emerges from the boat and should be grounded at its lower extreme end within the boat. Sp6tlights and other devices projecting through cabin tops should be solidly grounded regardless of any other type of lightning protection. Personnel should refrain from operating this gear when lightning is in the immediate vicinity.
- 3.45 Radio transmitter antenna should be (1) equipped with means for grounding during electrical storms or (2) the transmitter and antenna should be protected by transmitting type lightning arresters.
- 3.5 *Ground Connection* - A ground connection for a boat may consist of any metal surface which is normally submerged in the water and which has an area of at least one square foot. Propellers and metallic rudder surfaces may be used for this purpose. The ground plate as required by FCC for radio transmitters should be considered adequate. A steel hull itself constitutes an adequate ground.
- 3.6 *Vessel with Metal Hulls* - If there is an electrical contact between metal hulls and metal masts or other metallic superstructure no further protection against lightning is necessary. Boats with non-conducting or ungrounded objects projecting above the metal masts or superstructure should have these objects grounded in order to protect them.
- 4.0 *PROTECTION OF SAILBOATS*
- 4.1 *Sailboats* - Sailboats with metallic standing rigging will be adequately protected provided that all rigging is grounded, so that the mast and rigging meet the requirements of Section 3.1 and 32.
- 4.2 *Open Day-Sailers* - Open sailboats will be adequately protected if the shrouds and back stays or preventors are grounded. These should be electrically connected at the lower end and grounded to a copper plate on the hull or to a metal rudder, or center board or keel. *For the protection of personnel,* it is recommended that any continuous metallic track on the mast and boom be connected at the lower or forward end of the grounding system. *For protection of the boat only,* it is necessary to ground but one pair of shrouds.
- 4.3 *Cruising Sailboats* - All stays and all sail tracks should be grounded on cruising sailboats since it is assumed that persons will be in proximity of fore-stays as well as after-stays. Grounding of other objects on cruising boats should be in accordance with the foregoing paragraphs.
- 5.0 *PROTECTION OF POWER BOATS*
- 5.01 Power boats may be adequately protected by a grounded radio antenna or other suitably grounded lightning protective mast as specified in Section 3.1., provided the height of the mast meets the requirements for the specified cone of protection. Interconnection and grounding of metallic masses should be in accordance with this specification.
- 5.1 Where the size of the boat is such as to render the use of a single mast impractical, additional lightning protective masts should be erected to form overlapping cones of protection. It is recommended that the provisions of the United States Department of Commerce Handbook No.46 "Code for Protection Against Lightning" be followed.
- 6.0 *PROTECTION OF SMALL BOATS*
- 6.01 Small boats may be protected by means of a temporary lightning protective mast which may be erected under lightning conditions. Grounding provisions may be made by means of flexible copper wire and a submerged ground plate of approximately one square foot in area.

7.0 *SUGGESTED PRECAUTIONS FOR PERSONNEL*

7.01 Inasmuch as the basic purpose of protection against lightning is to insure the safety of personnel, it is appropriate that the following precautions be listed in this report.

7.1 One should remain inside a closed boat, as far as practical, during a lightning storm.

7.2 One should avoid making contact with any items connected to a lightning conductive system and especially in such a way as to bridge between these items. For example, it is undesirable that an operator be in contact with reversing gear levers and spotlight control handle at the same time.

7.3 No one should be in the water during a lightning storm.

7.4 If a boat has been struck by lightning, compasses and electrical gear should be checked to determine that no damage or change in calibration has taken place.

PICTURES OF BOATS WITH LIGHTING CONES GOES HERE

V. MAINTENANCE PROCEDURES

A. Engine: Perkins Diesel

Please consult your engine manual for detailed procedures. The engine manual must be followed exactly to obtain maximum engine life and to keep your warranty in effect. The following sections summarize the maintenance requirements described in the manual and are intended as general information only.

1. Break-in Period -
During the first twelve hours of operation, the engine should not be run at maximum RPM. At twelve hours, the following service should be performed.
 - a. Change engine oil and filter.
 - b. Tighten cylinder head nuts in correct sequence to correct torque.
 - c. Reset valve clearance and check oil feed to rockers.
 - d. Check belt tension.
 - e. Check all external nuts, set screws etc., for tightness.
 - f. Check shaft coupling alignment.
 - g. Check fuel, oil, and coolant levels and look for leaks.
 - h. Adjust idle speed, if necessary.

2. Before each outing -
 - a. Check coolant level.
 - b. Check engine oil level.
 - c. Check transmission oil level.
 - d. Look for evidence of leaks under engine.

3. Every 150 hours or 3 months (whichever occurs first) -
 - a. Change engine oil and filter.
 - b. Check drive belt tensions.
 - c. Clean air intake.
 - d. Clean motor trap
 - e. Look for evidence of leaks.

4. Every 450 hours or 12 months (whichever occurs first) -
 - a. All steps under item (3) above.
 - b. Change final fuel filter element.
 - c. Check hoses and clips.
 - d. Drain and clean fuel tank.
 - e. Change gearbox oil.
 - f. Service atomizers.

5. Every 2,400 hours -
 - a. Have Perkins representative examine and service proprietary equipment such as starter, generator, etc.
 - b. Adjust valve tip clearances.

Bleeding the fuel system -

- a. Check fuel tank shut-off to be "On".
- b. Check fuel filter for sediment or water by opening drain plug on bottom. Replace plug.
- c. Follow routing of hose from fuel filter to engine lift pump, inspecting hoses as you go. On the engine pump, you will find a lever which allows you to manually operate the diaphragm inside, against spring tendon. It may be necessary to turn the engine over with the starter slightly to allow the pump arm to relax against the camshaft. This allows more stroke with the manual lever you are operating.
- d. Follow the fuel line from the pump to the engine fuel filter and locate the vent plug on top. Loosen plug two or three turns.
- e. It is advisable to have some large rags on hand to catch oil that will be expelled from this point in the course of bleeding.
- f. Begin operating the manual lever. This may take several minutes as the filters will need to fill up (as well as the lines). Operate the manual lever until fuel flows freely from the filter plug with no signs of air bubbles.
- g. Loosen the two bleed screws on the injection pump (the head locking screw and the governor vent screw).
- h. Operate pump again until fuel flows freely with no bubbles.
- i. Re-tighten the vents beginning with the lowest point (the filter, the head locking screw, and the governor vent screw).
- j. Wipe up any spills at this time.
- k. Slacken the union nut at the injection nozzles.

- l. Move throttle to full RPM and check to see if the "Stop" control is in run position.
- m. Crank engine with starter motor until fuel flows from each injector. NOTE: Do not run starter motor continuously. It normally takes seconds of cranking to completely bleed the injector lines. Twenty seconds of cranking with about a two minute rest between periods will be easier on the starter, motor, and battery than steady cranking.
- n. Re-tighten injector lines, wipe spills
- o. Re-set throttle position and proceed with normal start-up.
- p. Allow sufficient running time to re-charge battery.

B. Drive Train:

1. Engine Alignment -

The propeller shaft of the OI-41 is 1-1/4" diameter, corrosion resistant, stainless "sealoy" supported by an intermediate bearing midway between the engine and the shaft log bearing.

The shaft is checked for accuracy initially at the factory during installation and is carefully aligned to the engine with the hull being properly supported and level. At this time, the shaft log and bearing is bonded to the hull penetration, and the position of the intermediate bearing is adjusted. The coupling to the engine is checked again for alignment by the commissioning dealer or agent prior to delivery of the boat. This alignment check should be made periodically, since the action of a rough sea could possibly change the shape of a boat enough to disturb engine alignment. If after the first rough water experience the alignment has not changed it is usually only necessary to make the check once per season. The coupling should always be disconnected before the boat is lifted out of the water, and alignment will then be necessary.

Prior to adjusting engine alignment, it is advisable to release the intermediate bearing from its supporting bulkhead to allow the shaft to move freely in all directions. Remove the bolts entirely from the bearing mount flange and proceed with the engine alignment.

The alignment is considered acceptable if there is a gap less than .0005" per inch of face diameter of the coupling (.002 for a 4" coupling, .0025 for a 5" coupling). The feeler gauge is inserted between the flanges at four points 90 degrees apart. Then check again keeping the engine coupling stationary and rotating the shaft coupling 90 degrees at a time. This checks the squareness of the coupling face to the shaft center line. The engine alignment is adjusted by raising and lowering the adjusting nuts at each mount. To make lateral adjustment, loosen the mounting pad screws which anchor the engine to the bed. You will note there are slots in the mount pad which allow a reasonable amount of adjustment side-to-side.

After adjusting and re-tightening all mount screws and lock nuts, double check the alignment.

In the absence of a feeler gauge the alignment can be checked fairly accurately with a strip of paper. Insert the paper between the two

halves of the outer flange and rotate both together 360 degrees. The paper should remain in place through the complete turn.

Upon completion of the engine alignment, replace the bearing mount bolts. Each bolt should fit in with a loose fit. To force any one bolt will cause the shaft to pull out of line. If the bolt will not pass through easily, re-drill the bulkhead holes. The purpose of the intermediate bearing is to prevent flexing or whipping of the shaft at higher RPM's.

2. Transmission -

The Perkins engine is equipped with a Borg Warner "Velvet Drive" hydraulic transmission. The transmission is a hydraulically operated "Multiple Disc" type clutch. The fluid used in this unit is Type "A" automatic transmission fluid (ATF) which can be obtained at any auto supply or service station.

The dipstick filler cap is on the port side of the transmission. It should be read immediately after stopping the engine to get an accurate check, as a certain amount will normally drain back from the oil cooler and lines. The dipstick assembly need not be threaded into the case to be gauged. It need only be inserted into the case until the cap or plug rests on the surface of the oil filler hole. Changing of the oil is recommended each season. The drain plug on the starboard side contains an oil screen which should also be cleaned at this time.

The position of the control lever on the transmission must be checked periodically, and an occasional lubricant applied to the external moving parts. The lever on the transmission, when in "Forward", should cover the letter "F" on the case casting. It is located in its proper position by the poppet ball. The control should be checked also in neutral and reverse. The manufacturer's warranty is cancelled if the shift lever is modified or if the linkage has insufficient travel in both directions.

Inspect the control cables for sharp bends and signs of damage, chafing, or corrosion. Check the lock nuts at the adjustments for tightness at both ends. Lubricate the moving parts with a spray lubricant or light grease.

3. Intermediate Bearing -
The intermediate bearing is equipped with a grease fitting. It should be lubricated each month or after 50 hours of operation.

4. Stuffing Box –

The stuffing box provides a seal for the propeller shaft at the inner end of the shaft log. It is connected to the shaft jog with heavy wall hose, double clamped at each end. This flex hose allows the stuffing box to maintain alignment with the prop shaft without creating excess wear of the packing due to misalignment or vibration.

The packing used is wax impregnated 3/16" x 3/16" square flax.

When the shaft is turning, it is normal to have a slight leakage at the seal. This acts as a coolant, as well as a lubricant, to protect the seal and shaft surface. Should excessive leakage be apparent, release the lock nut and tighten the packing nut slightly and re-tighten the lock nut. Re-start engine and check again with shaft turning.

When it becomes necessary to replace the packing (boat must be hauled out), loosen the lock nut, back off the packing gland nut, and slide it forward on the shaft. Remove all the old packing and replace it with three rings of new packing. Stagger the ends of each ring so as not to provide a path for water to leak through.

Do not wind one continuous strip spirally around prop shaft to make seal.

Slide the packing gland back and tighten enough to create a heavy drag on the shaft. This will seat and form the packing.

Back off the packing nut until the shaft feels free and re-set the nut. Re-check for proper leakage when boat is returned to the water. Be sure the lock nut is secure, as operating the boat in reverse could cause the packing gland to screw off the stuffing box, allowing water into the boat.

5. Optional shaft lock –

The optional shaft lock is a disc caliper type brake. The disc is installed between the shaft coupling and the engine drive flange. Operating a control knob on the pedestal causes the caliper to clamp the brake against both sides of the disc, locking the shaft from turning. A switch in the control assembly disconnects the starter circuit when the lock is applied.

The shaft being locked will prevent noise from the reduction gear and reduce wear in the transmission that is caused by a “windmilling” prop.

When needed, an occasional adjustment may be made at the transmission by loosening the cable clamp and taking out unwanted slack. Lubricate the pivot points of the lever periodically.

C. Exhaust System:

Check for leakage and proper supporting. The section of exhaust hose leading from the bulkhead to the aft thru-hull should be inspected for leakage at its connections. This hose should be supported to maintain a downward pitch aft to assure proper drainage. Look for physical damage to the hose, particularly at support points and/or bulkhead penetration.

D. Steering System:

1. Stuffing Box -

The rudder stuffing box is packed with a wax impregnated flax packing. The cap nut is packed with three rings of packing and tightened down on the upper bearing tube to the point where no leakage occurs. This fixture has a tapered thread and will hold its position when properly tightened and packed. Should the fitting leak and further tightening is not practical, remove cap and re-pack with new packing, spacing each successive ring so that the ends are 180 degrees apart.

2. Gudgeon Assembly -

Each time the yacht is hauled, carefully inspect the gudgeon assembly and all its fasteners for signs of physical damage and/or electrolysis.

3. Hydraulic Steering System -

The steering system in your OI-41 is relatively maintenance free, except for visually checking it over for loss of fluid through leakage and an occasional lubrication of the pivot pin at the rudder tiller arm under the aft bunk. The reservoir, relief valve, and actuating cylinder are accessible through a drop-in panel under the aft bunk cushion.

The fluid used in the steering system is ML-H-5606 aircraft hydraulic fluid.

Normal reservoir pressure should be maintained at approximately 20 psi. A thorough check of all mechanical linkages and support brackets should be made every 3 to 6 months or whenever any yard work has been done in an area that could affect the steering system.

Instructions for purging air from the system will be found in the Hynautic's owner manual. For your convenience, the instructions taken from the manual are repeated below:

“Remove the filler plug from the reservoir, taking care not to damage the gauge. Fill to within 3" of the top of the sight glass with aircraft ML-H-5606 hydraulic fluid, or Type "A" automatic transmission fluid may be substituted.

Loosen the two valve screws on the relief valve by turning them counterclockwise (with a screwdriver or 9/16" wrench) until pressure is removed from spring. (Be careful not to unscrew it completely or the screw could become lost).

With filler cap in place, pump the reservoir to 55 psi. Oil will start flowing into the lines, and the pressure and fluid level will drop. Keep pumping air into the system until the pressure holds fairly constant. Should the fluid level drop to approximately 2" from the bottom of the reservoir, refill the reservoir with fluid and repressurize. If the pressure and fluid levels are not holding fairly constant after a few minutes, it is better to check for leakage at all joints.

Next, go to the helm at the highest level and turn 10 to 20 turns starboard, pumping the air out of the lines and back to the reservoir. In three to five minutes you should be able to feel and hear oil coming into the pumps

Again the pressure and oil level should be checked. The fluid level should not drop below 2" level in the sightglass. If the fluid level is low, the reservoir should be filled to within 3" of the top before it is again pumped to 55 psi. Do not overfill, as the 3" capacity in volume of air is needed.

If one station is involved, it should require only 5 minutes of purging. Since the sintered bronze filter extends up into the reservoir about 2", it is necessary to keep the oil level above the filter to prevent air from being pumped back into the system.

Keep the air pressure at approximately 55 psi during this time and turn the wheel 20 turns each way.

As a progress check, close the valve screws on the relief valve and see how many turns are required from hard over to hard over. It will likely be necessary to close and then to open a half turn on the valve screw at this time to make certain the cylinder is stroking to purge all the air from the cylinder.

With the valve screws open 1/2 turn, pressure can be built up in the system which will cause the slave cylinder to stroke. If a second steering station is in the system, it will be necessary to purge it the same as the first. It should not require as much time since the lines and cylinder are now filled with oil. Several quarts of oil may be required for a large boat.

Again we should check for oil leaks. If a line needs to be disconnected for any reason, let the air pressure out of the reservoir before disconnecting the line. If it is now determined that the proper number of turns lock to lock have been obtained, we should recheck the oil level, and leave 20 psi of pressure on the system.

Close the valve screws on the relief valve.

When checking the number of turns, note that it is possible to pump over the relief valve (factory set is 750 psi). This provides a safety feature for expansion.”

E. Electrical System:

1. Preventive Maintenance -

Electrical systems are adversely affected by moisture and a salt air environment. Preventive maintenance consists of protecting the system from the elements and periodic inspection for damage created by the elements.

There are numerous aerosol spray products available for moisture-proofing terminals and connections. RTV Silicone can also be used. The silicone provides a more permanent seal, but is more difficult to remove should you wish to disconnect the wiring. If RTV silicone is used, it should be a transparent grade so that the connection will be visible through the sealant.

Periodically check all wire harnesses and connections for secure fastening, cleanliness, and any signs of physical damage or corrosion. All terminals should be clean and bright at their mating surfaces. A dirty or corroded contact area will cause resistance, and, depending on the load attempting to pass through, generate heat. This, in turn, increases resistance and will eventually burn the terminal with a resulting failure of the circuit. Battery drainage and possible electrolysis problems will occur prior to the circuit failure. Thus, it is extremely important that connections be kept clean. Correct any problems detected in the inspection.

Caution: Do not perform any maintenance or repair functions "live circuit". Be certain that the battery switch is off when working on the 12 volt system and the 110 volt main breaker is off when working on the 110 volt system. It is also a good practice to remove all metal jewelry (rings, watches, wristbands, etc.) when working near the batteries or on any electrical component.

2. Repair-

Refer to the schematics shown in the last section of the Owner's Manual in trouble shooting and repairing electrical system problems.

With the exception of the engine harness (connector plug at the engine) and the mast harness (connector at the mast step), the wire runs are continuous from point to point.

The wiring is color coded to A.B.Y.C. recommendations. The following list describes the color coding system used in your yacht.

Interior Harness:

- Red - All feed circuits (from source of power)- positive
- Black - All return circuits (ground)-negative
- Green - All bonding circuits (non-current-carrying) static ground
- White - Navigation lights
- Blue - Cabin lights
- Brown - Pumps
- Orange - Accessory circuits

Engine Harness:

- Purple - Ignition and/or instrument freed
- Tan - Temperature gauge
- Blue - Oil pressure gauge
- White - Starter solenoid circuit
- Green - Diesel pre-heat option
- Gray - Tachometer (electric)
- Dk. Blue - Engine instrument lights
- Orange - Alternator output

Mast Harness:

- Red - Masthead light
- White - Bow light
- Green - Spreader or foredeck light
- Black - Ground

V MAINTENANCE PROCEDURES

E. Electrical System (continued)

3. GFCI Protection

The receptacles in the head and galley areas are equipped with ground-fault circuit interrupter devices. The GFCI receptacle is usually located in the galley, and other receptacles connected to this one will also be protected by this device. A test and re-set button is provided on the unit, and instructions for testing should be found adjacent to outlet or on main breaker panel.

The purpose of this device is to provide protection against the hazards of ground-fault currents that can cause loss of life. An example of ground fault current is the current that would flow through a person who is using an appliance with faulty insulation and at the same time is in contact with an electrical ground such as a plumbing fixture or wet floor.

Even with GFCI protection, an electric shock may be felt, but such shock will be less dangerous. The GFCI does not protect a person who contacts both the hot and neutral wire. There is no known device that can offer complete protection against electrical accidents under all conceivable conditions. There is no substitute for remembering that electricity is dangerous when handled carelessly or misused.

The GFCI is not an overload type of circuit breaker, but senses an unbalanced condition between the "hot" and neutral circuit and immediately interrupts the circuit.

When the GFCI circuit opens, all other receptacles down line from it will also be "off". Remove the appliance at fault and re-set the button on GFCI unit to restore service.

Test the circuit frequently as instructed by the manufacturer or at least every 30 days.

G. Deck Hardware:

All deck hardware should be rinsed off with fresh water after each outing and periodically washed with a soap or detergent solution. See section on finishes for additional information on care of deck hardware finishes. This section is concerned with lubrication and inspection of the deck hardware.

1. Winches -

- a. Monthly: All winches should be lightly oiled and greased.
- b. Two or three times during season: All winches should be stripped, cleaned, inspected and relubricated.
- c. Start and end of season: Complete strip, clean, inspection, lubrication. Inspect mounting bolts for proper seal and tightness.

Follow detailed procedures given in the Lewmar Manual I

2. Blocks -

- a. Inspect periodically for cracks, burrs, or other physical damage. Burrs can be removed with a file and emery paper. If the block is structurally damaged, replace it immediately.
- b. If the block is equipped with a removable sheave, remove and lubricate with Lubriplate Marine Lube "A". If not removable, oil shaft with SAE 30 oil.

3. Lifelines-

Inspect lifelines, stanchions, and pulpits at least once a month. The following should be checked, with any needed corrections made immediately.

- a. Lifelines properly tensioned

Maintenance Procedures (cont.)

- b. Turnbuckles lubricated, pinned, and raped. All locking devices present.
- c. Plastic coating intact.
- d. Look for bulges or deformity in the plastic coating. This usually indicates rust or corrosion damage. Remove vinyl in this area and inspect wire. If wire is O.K., wrap the wire with rigging tape.
- e. Inspect swage fitting. Look for cracks and/or corrosion damage on the fitting and the wire.
- f. Check eyelets on pulpits for structural integrity.
- g. Check all set screws on pulpit and/or stanchion bases.
- h. Examine stanchions and pulpits for structural damage and secure attachment to the deck.

4. Deck Hardware Mounting –

Periodically check the tightness of all bolts used to attach the toe rail and all deck hardware. In the process, inspect for proper hardware seating and look for signs of loose or missing bedding. If small sections of bedding are missing, silicone can often be applied locally. If the sealant problem is more extensive, remove, re-bed, and re-install the piece of hardware.

While sailing, observe the individual pieces of hardware as stress is applied. Look for any signs of movement

5. Roller Furling Gear -

a. Schaefer:

The standard Schaefer system requires only periodic oil at the swivel points.

Use SAE 30 oil. Check the entire system for signs of wear or physical damage at least once a month.

b. Optional Hyde Stream Stay:

Once a year, or more frequently if you detect any binding, disassemble the unit to clean and lubricate with Lubriplate 1200-2-WBG or an equivalent non-fibrous wheel bearing grease. Follow the instructions in the Hyde Manual. Inspect the entire system for signs of physical damage at least once a month.

6. Running Lights –

Check that all lights operate before each outing.

At least once a month, carefully inspect the fixtures for cracks or obstructions in the lenses, any signs of failure of the sealing gasket, and any signs of corrosion on the bulb, bulb socket, electrical wires, or connectors. If the bulb is removed, spray the bulb base and the socket with WD-40 or CRC 6-66 before re-installing.

H. Spars and Rigging:

Care and protection of finishes on the spars and rigging are discussed in the next sub-section. Listed below are inspections which should be made at least once a month during the active season

1. Check fasteners for damage and rightness.
2. Ensure blocks, tracks, sheaves, swivels, and pins are lubricated and operate freely.
3. Check sheaves and travelers for burrs. Emery paper and file will rid burrs.
4. Make sure sail tracks are straight.
5. Check fairleads and blocks for burrs and oxidation. File and emery paper will fix both conditions.
6. Check cleats for cracks and burrs - if cracked, replace 'immediately.
7. Examine and carefully check main boom and/or mizzen boom gooseneck, pin, cotters, and welds. If welds are cracked, professional attention is required immediately.
8. Examine chain plates for damaged eyelet (egg shaped) or cracks and to be sure they fair in line with shrouds. If cracks or eyelet damage occurs, replace chain plate (professional attention).
9. Be sure that turnbuckles turn freely, cotters are O.K., and threads are lubricated and undamaged.
10. Check shrouds and stays for broken wires, chafing, and fair leading to chain plates. Check end fittings for cracks, corrosion, and any signs of wire slippage. Defects found in any of these areas require professional attention and/or replacement of the defective part.
11. Check all sheets and halyards for fraying and/or burrs. For isolated burrs, cut the burr off and tape over section. If numerous burrs occur, replace halyard and determine why burrs occurred. Raveled or frayed sheet ends, etc., need only to be whipped and burned. Burning melts ends and prevents unraveling.

12. Examine all wire to rope splices to ensure splice is intact. Professional attention is usually required to replace a wire to rope splice.

I

)

I.. Finishes:

1. Fiberglass -

The exterior surface of all of the fiberglass components on your yacht is polyester gel coat. Morgan Yacht uses only the best grade marine gel coats available. The base resin is isophthalic and/or NPG type which offers the best combination of initial gloss, resistance to weathering effects, and resistance to cracking and blistering. The pigments are carefully selected for color stability, color purity, and resistance to color float. All of the formulations include ultra-violet inhibitors and acrylic monomer which further reduce the effects of weathering. Even the best gel coats are not totally immune to the elements. As a general rule, you should treat the gel coat surfaces of your yacht as you would your car's finish. The following procedures will maximize the useful life of the gel coat:

- After every outing rinse off the deck and topsides with fresh water.
- At frequent intervals wash all fiberglass surfaces with a mild detergent or car wash solution. Use a sponge or towel on the high gloss areas. A brush may be used on non-skid areas. Always rinse thoroughly with fresh water.
- Apply wax to the glossy areas at least once a year and more frequently if the yacht is in southern waters. Do not apply wax to non-skid surface areas or the textured portions of the headliner. A good grade automotive wax specially formulated for fiberglass surfaces may be used. Follow the instructions on the can.

If the wax contains cleaners, extreme care must be taken if a power buffer is used. The cleaners are often abrasive which may remove some of the gel surface. Holding a power buffer too long in one spot, particularly on sharp radii, can result in "going through" the gel.

The preferred procedure is to use a wax with cleaners and to buff by hand with turkish towels. This method is a bit more work, but it results in removal of surface oxidation without risking excessive gel coat removal.

If the surface becomes dull due to lack of routine care or aging, it can often be restored by hand buffing with an automotive rubbing compound such as Dupont Number 7 followed by a coat of wax. The compound will remove some of the gel coat. Extreme care must be taken so as not to penetrate the gel layer. The factory applies gel at a thickness of 18 to 25 mils (paint films are generally 1 to 4 mils), and gel coats normally provide full hiding power at thicknesses as low as 8 to 10 mils. Thus, there is some margin for gel coat removal without adversely affecting the appearance of the surface.

If rubbing compound does not restore its gloss, the surface may be sanded with 320 grit paper, then sanded with 400 grit paper, polished with rubbing compound or polishing compound, and finally waxed. This procedure can result in substantial gel removal and requires extreme care. Generally, this remedy should be undertaken by a yard experienced in fiberglass repairs. Even then, you should be prepared for the possible need to paint if the operator goes too deep in some areas.

Fiberglass surfaces may be painted, and there are several types of paint specifically formulated for resurfacing gel coated substrates. For the ultimate in gloss and weather resistance, we recommend a top quality two-part urethane (e.g., Dupont Imron available at paint stores). Two-part epoxies also provide glossy and durable finishes, but they may chalk with aging.

Scratches, nicks, or other surface damage which cuts deeply into the gel or penetrates to the laminate should generally be repaired by a competent yard. If you choose to do this work yourself, contact the factory for recommended procedures.

Caution: Gel coats resist most chemicals, but they are not resistant to strong caustics, strong oxidizing compounds, or some halogenated compounds. Materials which should be kept away from gel surfaces include:

- Paint remover containing sodium hydroxide chloride
- Bleaches containing chlorine
- Cleaners containing chlorine or hydroxides
- Methylene chloride or carbon tetrachloride solvents
- Chloro-bromomethane fire extinguishers

Caution: Abrasive Cleaners should not be used for routine cleaning operations, since they result in gel coat removal and may leave scratches.

2. Vinyl Hull Liner and Bulkhead Covering -

Vinyl liners used in your yacht are fire retardant, mildew resistant, and are selected for durability in marine environments. Other than occasional cleaning with a mild detergent, they are maintenance free.

The vinyl is applied at the factory with contact cement. Should a corner or edge come loose, it can be re-attached with contact cement.

The vinyl will not withstand rubbing with strong abrasives or solvents such as acetone or methylene chloride. Mineral spirits may be used as a solvent if care is taken not to let it set on the surface.

3. High Pressure Laminate Surfaces -

The mica surfaces require only occasional cleaning with a mild detergent. Household cleaner/waxes such as Pledge may be used and will mask small scratches that may occur. Do not use strong abrasive cleaners on mica, as they may dull the surface.

4. Upholstery Fabrics -

The fabric in your yacht is Herculon. The suede trim is a special type of cloth backed vinyl. Both materials are self extinguishing and mildew resistant. Both may be cleaned with household upholstery shampoo. Follow the instructions on the can. Care should be taken not to allow excessive liquid penetration into the foam since it takes a long time to dry.

The cushion covers are removable and may be dry cleaned.

5. Spars -

The spars on your yacht are finished by a glass bead peening process. This method is used in the aircraft industry but is unique to Morgan Yacht in our industry. The peening process provides a tempered surface on the aluminum and a very substantial increase in corrosion resistance. As a final step the spars are waxed before they leave the plant.

To protect the finish on your spars, the following steps are recommended:

- Rinse off spars with fresh water after each outing.
- Tie the halyards away from the spar when not in use; not only does this prevent abrasion on the spar and halyards, but it eliminates the annoying slapping noise caused by the boat's movement.
- At least once a year, and more frequently in southern waters, wax the spars with a good grade automotive wax.

Morgan Yacht does not paint the spars because of the inherent problems of nicks, scratches, and the resultant increased maintenance effort required to assure color uniformity. The peening process does not affect the paintability of the spars, but the factory applied wax does. If you decide to paint the spars, be sure that the factory applied wax is completely removed first. We suggest two-part urethane (e.g., DuPont Imron or Awlgrip) for maximum durability. Be sure to follow the manufacturer's recommendation in prepping, priming, and painting aluminum surfaces. Shortcuts can result in poor paint adhesion.

6. Aluminum Hardware –

Periodic cleaning and waxing with automotive type wax is the only surface maintenance required. If the surface becomes pitted, emery paper and polishing compound may be used to remove or reduce the prominence of pits. This will remove the anodized surface and it will be more important than ever to keep the polished surfaces well waxed.

Caution: Do not use emery paper or polishing compound on black anodized aluminum surfaces. Black paint will mask scratches in the anodized surface.

7. Stainless Steel Rigging and Hardware -

All of the stainless steel components and rigging are 304 or 316 grade which offers maximum corrosion and rust resistance in a salt water environment. To maintain the stainless steel surfaces, the following steps are recommended:

- After each outing hose down the rigging and hardware with fresh water.
- Occasionally polish stainless steel surfaces with metal polish.
- At layup or before prolonged periods of disuse apply automotive wax to stainless steel hardware. Wax should not be used on the wire rope rigging.

8. Chrome Plated Bronze Hardware -

Rinse with fresh water after each outing and clean as needed with automotive chrome polish. Wax with automotive wax at least once a year, preferably before lay-up.

9. Boot and Sheer Stripe

The boot and sheer stripe are painted on with Amerflint two-part epoxy or DuPont Immn two-part polyurethane. Routine maintenance is identical to that of the gel surfaces. Minor scratches or nicks can be touched up with automotive enamel or lacquer. A complete re-spray, if needed, should be done with a two-part epoxy or two-part urethane for maximum adhesion and long life.

10. Bottom Paint

The selection of type and brand of bottom paint will depend on local water conditions and your personal preference. To allow you maximum flexibility, the yacht is delivered new to you with an unprimed and unsanded bottom.

The key to a good bottom job is close adherence to the instructions on the paint can. Do not shortcut the cleaning or priming operations. Apply the recommended number of coats of paint and launch within the recommended time after painting. Because the materials are expensive and bottom preparation is hard and dirty work, there is always the temptation to do a little less than the paint manufacturer asks for. But remember, premature failure will require re-doing the job and the additional expense of a haul-out.

The expected life of anti-foulant will vary significantly with water temperature, water salinity, local harbor conditions, the relative amount of use the yacht gets, and the particular owner's definition of the amount of growth that constitutes a need for removal. Under average conditions you can expect to run six to twelve months between renewals.

Before repainting the bottom, it is necessary that all marine growth is removed, that the bottom is thoroughly sanded, and that the bottom is absolutely dry. At least twenty-four hours should be allowed after hauling to assure dryness. If, in scraping off the marine growth the paint is removed down to the gel, be sure the gel is thoroughly sanded so that all gloss is removed. If the gel itself is penetrated, seal with polyester resin or gelcoat before painting. If applying the paint, follow the instructions on the can.

Caution: The sanding dust from anti-foulant paint is toxic. A face mask, goggles, rubber gloves, and suitable protective clothing should be worn during sanding operations. After sanding wash up thoroughly and clean dust from your tools.

It is also advisable to wear an organic vapor cartridge mask and goggles while applying the paint. Wash up thoroughly after painting.

11. Lexan and Plexiglass

All of the exterior glazing (portlights and hatches) are Lexan polycarbonate. Some of the sliding doors and mirrors below are Plexiglass. Both materials are extremely tough and have the advantage over glass of resistance to shattering if broken. However, both materials exhibit lower chemical resistance and abrasion resistance

than glass. As a result, care is needed in cleaning these materials.

For general cleaning, a turkish towel dampened with a mild detergent solution is recommended. If the surface dirt is gritty, flush first with water. Never use acetone or other keytone solvents on either material. Never use abrasive cleaners oneither material.

Minor scratches can be removed by hand buffing with jewelers rouge or cleaners specifically formulated for plastics. (Aircraft or motorcycle service centers are good sources for these cleaners.) Some scratches can be removed by hand buffing with toothpaste and water.

12. Teak Joinerwork –

Teak is used for all exterior and interior trim. Teak veneer plywood is used for all woodgrain interior joinerwork panels and on the main cabin sole. All of the teak is hand rubbed and oiled before the yacht leaves the plant.

There are several options open to you on maintaining teak. Your choice will depend on your preference in the aesthetic appearance of the bright work and the amount of time and/or money you are willing to devote to bright work maintenance. Some of the alternatives are described below:

a. Leaving teak untreated:

Teak contains a natural oil which is one of the reasons it is so durable in a marine environment. As it ages, however, the oil exudes to the surface and disappears. (Direct sunlight speeds up the process.) When teak weathers, it takes on a silver gray color which many find attractive. The disadvantage of weathered teak is that the grain raises, and there is a tendency for the teak to check and split. Periodic cleaning with commercially available teak cleaners, such as Teak-Brite, will restore the original color and improve the aging characteristics of the teak.

b. Oiling teak:

Periodic oiling of the teak will help maintain the golden brown teak color and greatly increase the resistance to checking and

splitting by replenishing the natural oil in the teak. Special oils (e.g., Teak-Brite Sealer and Watco Teak Oil) have been formulated for finishing teak. These are generally preferred over Boiled Linseed Oil, because they contain toxicants for mildew resistance and other additives. Boiled Linseed Oil may be used on teak, but more frequent cleaning and re-oiling may be required.

The general procedure is to clean the teak (see above) and sand if necessary, then apply oil liberally with a rag. Re-apply oil until it is no longer absorbed into the surface. Allow oil to penetrate for 15 to 30 minutes and then wipe off with turkish towel. Rub in the direction of the grain. Be sure to observe any special instructions on the can label.

c. Varnishing teak:

A varnish finish provides the best protection for the teak, and most people agree that a varnish greatly enhances the appearance of the teak. The drawbacks to varnishing teak are the high initial cost (labor content) in obtaining a first rate job and the comparatively high maintenance effort needed. Exterior varnished teak will normally require a new coat of varnish every four months, and interior joinerwork will require recoating at least every two years. If the varnish fails (peels, yellows, crazes, etc.) before recoating, extensive sanding is required; and often the entire finish must be removed and redone.

The main forces which work against a good varnish job on teak are dust, moisture, grain in the wood, and the natural oil in the teak. Their effects and avoidance techniques are discussed briefly below:

- (1) Dust - Varnish must be sanded between coats, and the sanding dust must be removed before recoating. Wipe all sanded surfaces with tack cloths, and then thoroughly vacuum the surrounding areas before varnishing. Brushes must be thoroughly cleaned, and the varnish should be strained before using. Varnish remaining in the can after completing a coat should be discarded. This eliminates dust accumulation in the can and eliminates the problems of surface skinning in the can. Varnishing must be done on a still day.

- (2) Moisture - Moisture will cause varnish to blush and/or lift. Be sure all surfaces are absolutely dry before varnishing. Do not apply varnish when the humidity is high or rain is forecast within 16 hours after application.
- (3) Grain - Teak has a sharply defined grain which will telegraph through several coats of varnish if the preparation is incomplete. The teak should be block sanded to a 150 grit finish. Take care on the panel surfaces not to penetrate the veneer, but strive to obtain a smooth surface everywhere. For best results, a “paste wood filler” or “filler stain” (Petit and Interlux both offer easy-to-use materials.) should be used to fill the grain. Follow the instructions on the can to the letter.
- (4) Natural Oil in the Teak - The natural oil in the teak exudes to the surface with aging. This helps protect unvarnished surfaces. It can destroy varnished surfaces by causing lifting. To minimize the risk of lifting, wash all teak surfaces to be varnished with acetone prior to the initial sanding.

Use plenty of acetone and change wiping rags frequently.

Caution: Acetone is extremely flammable. Be sure area is well ventilated and that all potential sources of spark or open flame are eliminated before using acetone. Do small areas at a time. Then allow the area to clear itself of vapors before continuing.

A thorough discussion of varnishing techniques is beyond the scope of this manual. Prior to tackling the job of varnishing your yacht, you should talk to experienced varnishers. Read the various publications issued by varnish manufacturers, and by all means follow the instructions on the can to the letter. Listed below are the steps that will be required to get a top quality finish. The listing is useful as a checklist of the major steps to be undertaken:

- Wash teak with acetone.
- Sand to 150 grit finish.
- Fill grain with filler stain.

Maintenance Procedures (cont.)

- Apply sealer coat - sand lightly
- Apply three to seven coats of varnish, sanding between coats with 150 grit paper.
- Apply last coat. If a satin finish is desired, use satin varnish for last coat or apply high gloss varnish and rub with pumice and boiled linseed oil.

J. Sail Care:

To help you obtain the best continued service and longest useful life from your sails, we would like to offer this advice for sail care. Good sail care is not difficult or particularly time consuming. Over a period of years, a little conscientious care can save hundreds of dollars.

Sail care for synthetic sails consists of three basic elements: cleanliness, protection from unnecessary ultraviolet radiation, and proper usage.

1. First, your sails should be kept clean. Simple flushing with fresh water will normally do this job. Once a year, or more often if necessary, a thorough washing using a mild detergent will keep your sails white and free of salt that can cause abrasive damage to sail fibers over a period of time.

Sails may be spread on a smooth clean surface and scrubbed to remove imbedded dirt; but simply soaking the sails in a detergent solution with occasional stirring is preferable since it avoids any chafing of the sail against a surface. In any case, do not put your sails in a washing machine. You will get your sails clean at the expense of a great deal of cloth damage from slides and snaps working against the cloth.

Occasionally your sails may be stained, in which case, there are several commercial stain removers that can be safely used; but, be certain that the instructions verify that the product is safe for Dacron or Nylon.

2. Secondly, the most destructive force to synthetic sails is ultra-violet radiation. The important thing to remember here is to keep your sails out of the sun except when in use. Use a mainsail cover if you leave the sail on the boom. Never leave your sails lying on a flat surface in direct exposure to the sun. One hour on the clubhouse lawn can have the same destructive effect as a weekend's racing.

After you have washed your sails, hang them up by the luff in the shade when possible. Put them under cover as soon as they are dry.

3. Finally, proper usage consists of protection from chafing, proper storage, and prevention of over-stretch.

- a. Prevention of chafe is a common sense thing. Check spreader tips, turnbuckles, stanchions, pulpits, and other parts of the boat and rigging which may come in contact with the sails. Some fittings, such as spreader tips, can be taped or covered with leather. Others, such as screw heads, should be filed smooth. A periodic inspection of the sails will help pinpoint sources of chafe or sharp edges that may eventually tear a sail or cut the stitching.
- b. All sails should be stored dry. Dacron sails should be folded, but they don't have to be. Soft unfilled sail cloth suffers little from "stuffing", since there is no filler breakdown from the repeated creasing. However, even soft cloth enjoys a longer life with folding, since folding and rolling of sails will minimize creases and strains on the fibers. Folded sails also require less space for storage and set more smoothly in light airs. Long term storage should especially be in a folded condition and in a cool, dry place. Never leave the battens in the main when it is not being used. The cloth, elastic, and battens will all suffer,
- c. Finally, proper use involves using the sail in its proper conditions. Using a 4 oz., 170% genoa on the 40 footer in 18 knots is obviously going to strain the sail and distort the shape. Unfortunately, there are no standard tables indicating the exact wind velocity at which the headsails should be changed. Sea conditions, stability of the particular boat, cloth weight, and sail shape are determining factors that all affect the decision to change sail.

While we can give you guide lines for any individual sail; ultimately, your judgment is going to be called upon. Watch the sail for signs of strain or distortion of its airfoil shape. Remember that sails are made of cloth; and, while modern synthetics are extraordinarily strong, they do have limits. Sails can be ruined by carrying them in winds beyond that for which they were designed, stretching a leech over a spreader, stretching the foot over the shrouds or a life line, allowing leech flutter uncontrolled, and excessive luffing.

This is by no means a complete treatment of sail care. But, with common sense and the general care we have outlined, your sails will give you years of trouble-free service.

VI. Charts and Drawings

The drawings which follow are for descriptive purposes only and not to scale. They are not intended to be used as construction drawings.

The location of some accessories may vary on your yacht from the drawings due to engineering changes or the particular combination of options on your yacht. Consult your dealer on any discrepancies you may discover.

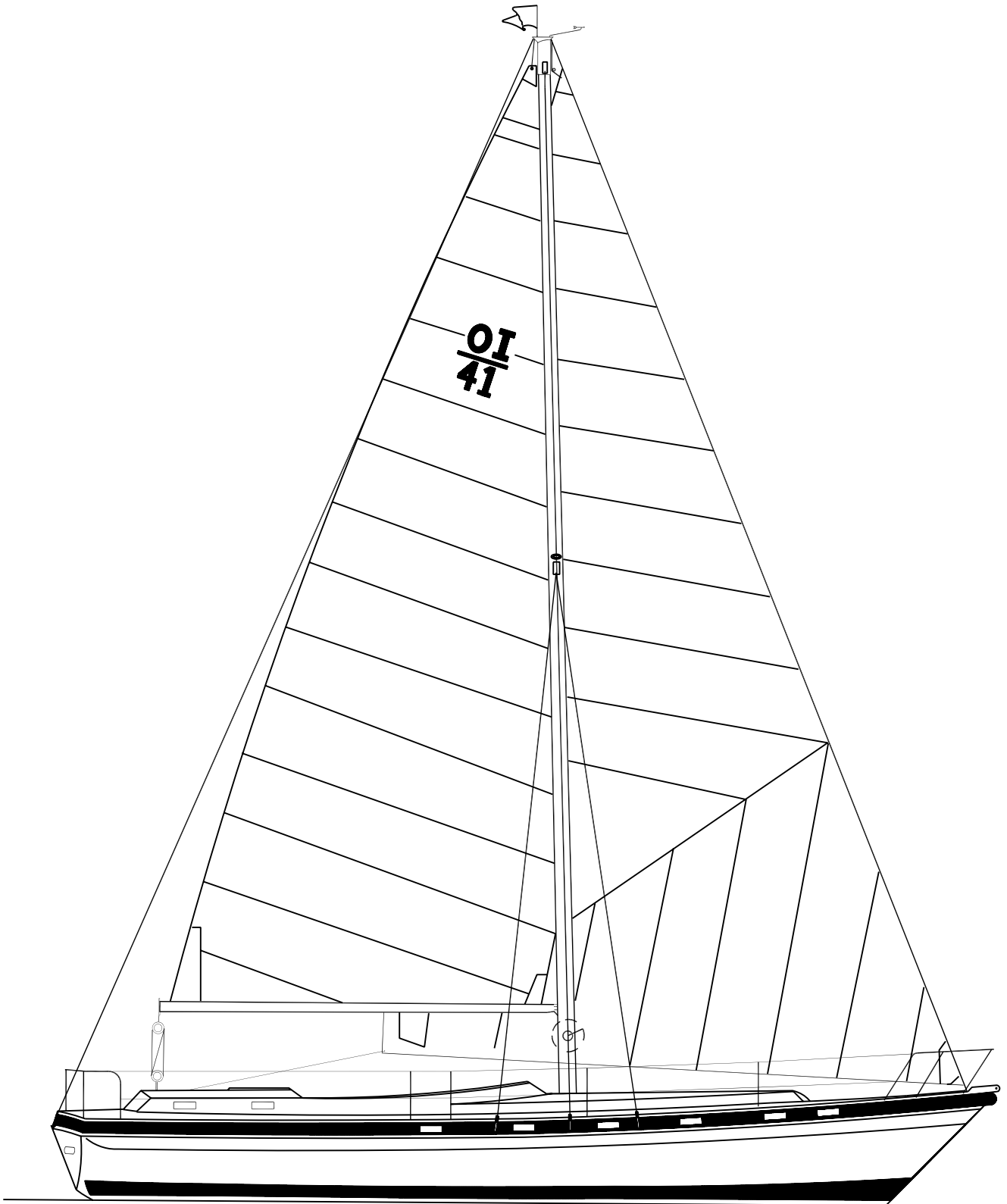

Out Island 414 & 415
Outboard Profile & SailPlan
Sloop Rig

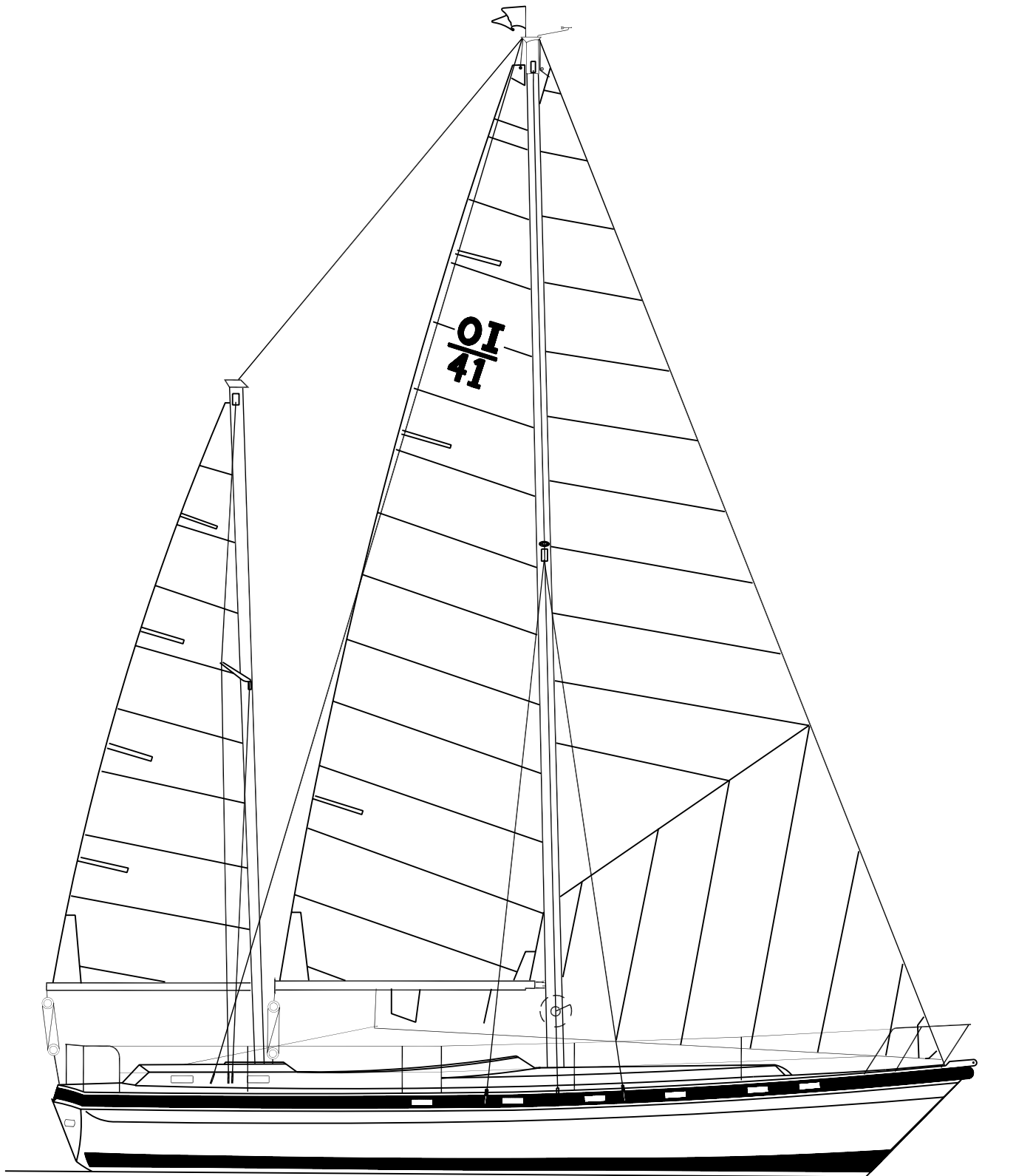

Out Island 414 & 415
Outboard Profile & SailPlan
Ketch Rig

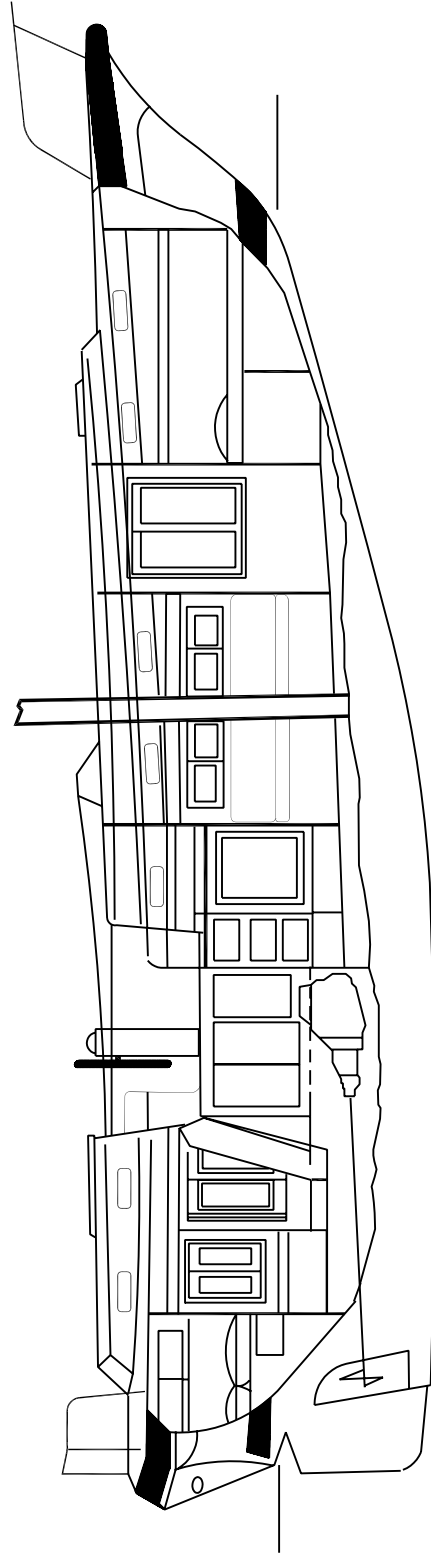
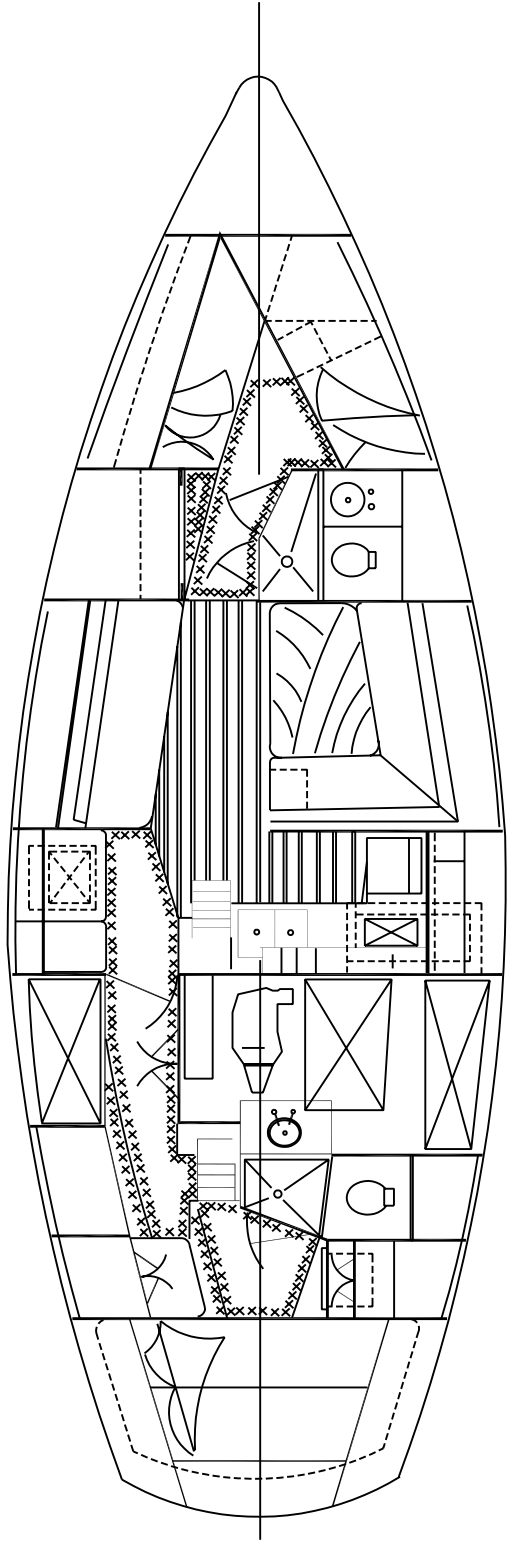

Out Island 415
Arrangement & Profile

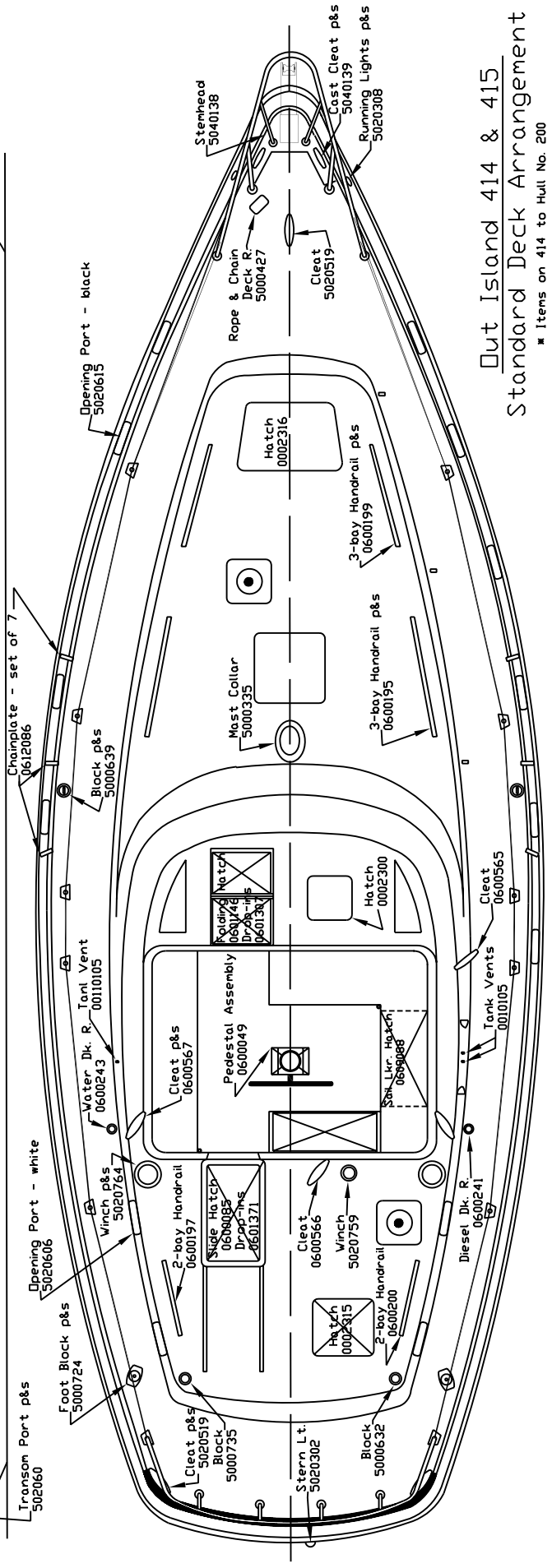
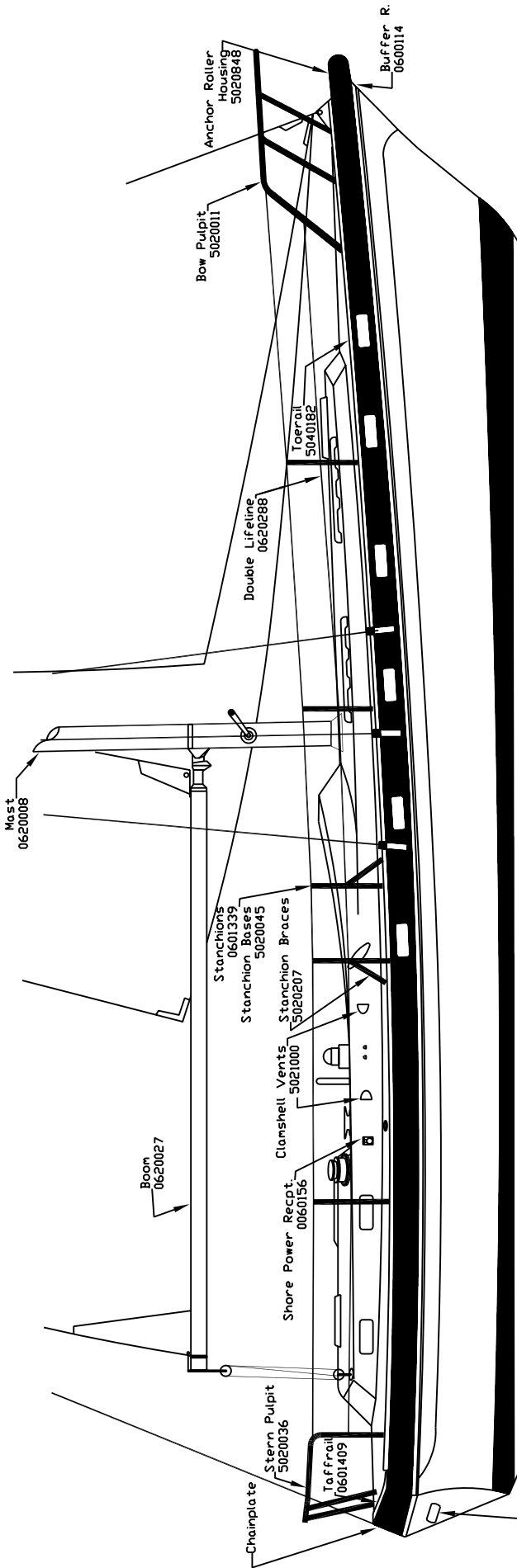

Out Island 414 & 415
 Standard Deck Arrangement

* Items on 414 to Hull No. 200

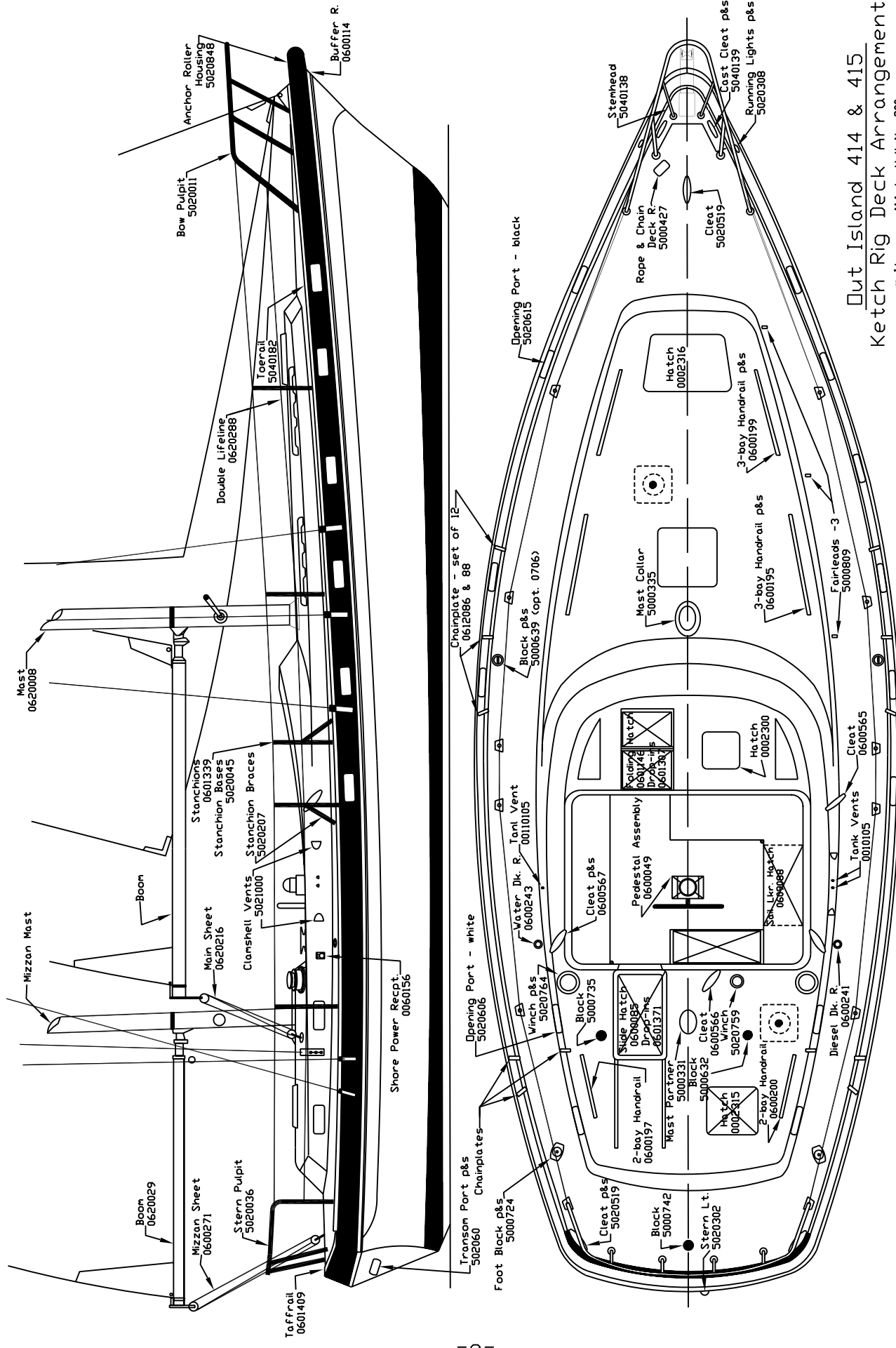

Out Island 414 & 415
 Ketch Rig Deck Arrangement
 * Items on 414 to Hull No. 200

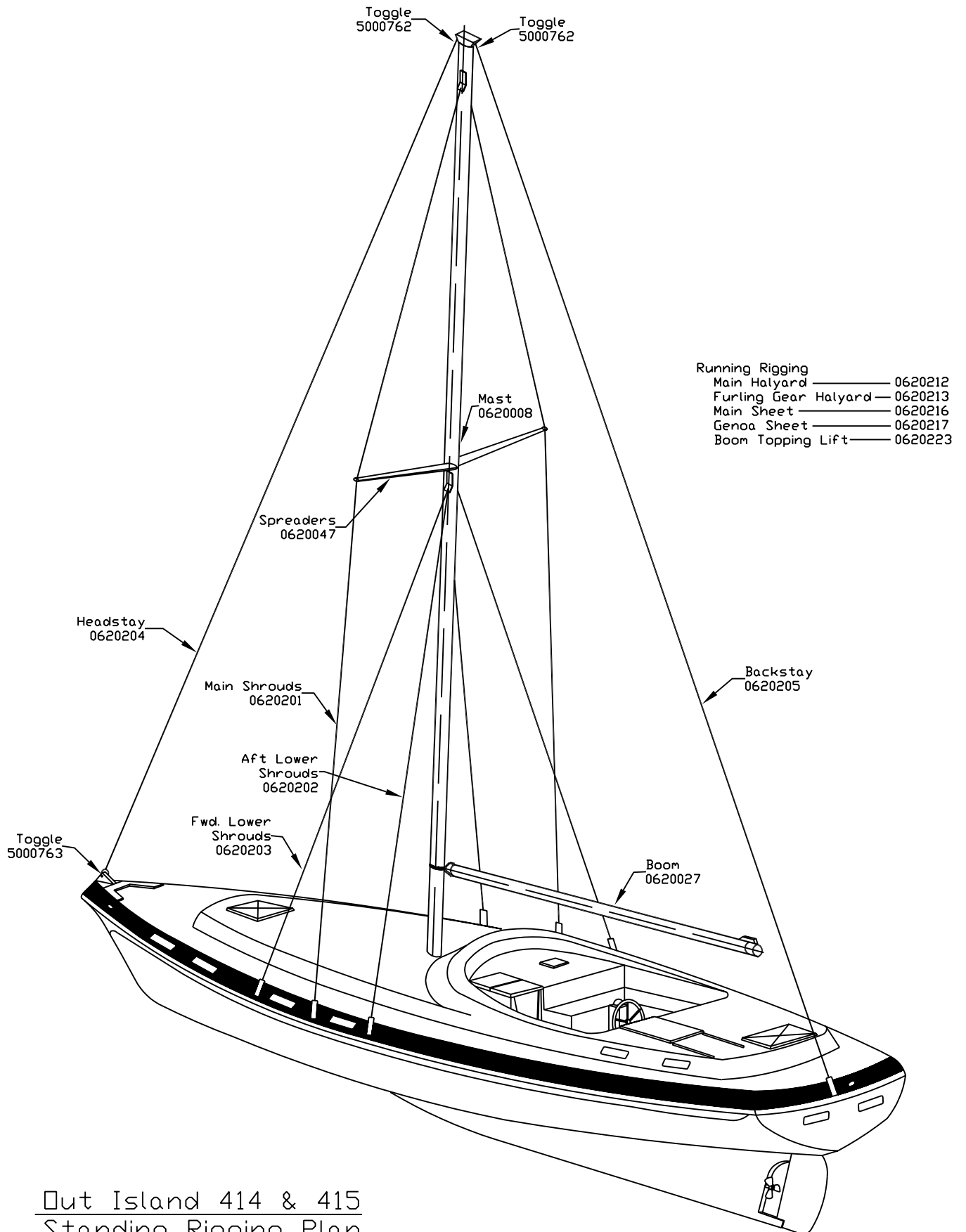

Out Island 414 & 415
Standing Rigging Plan

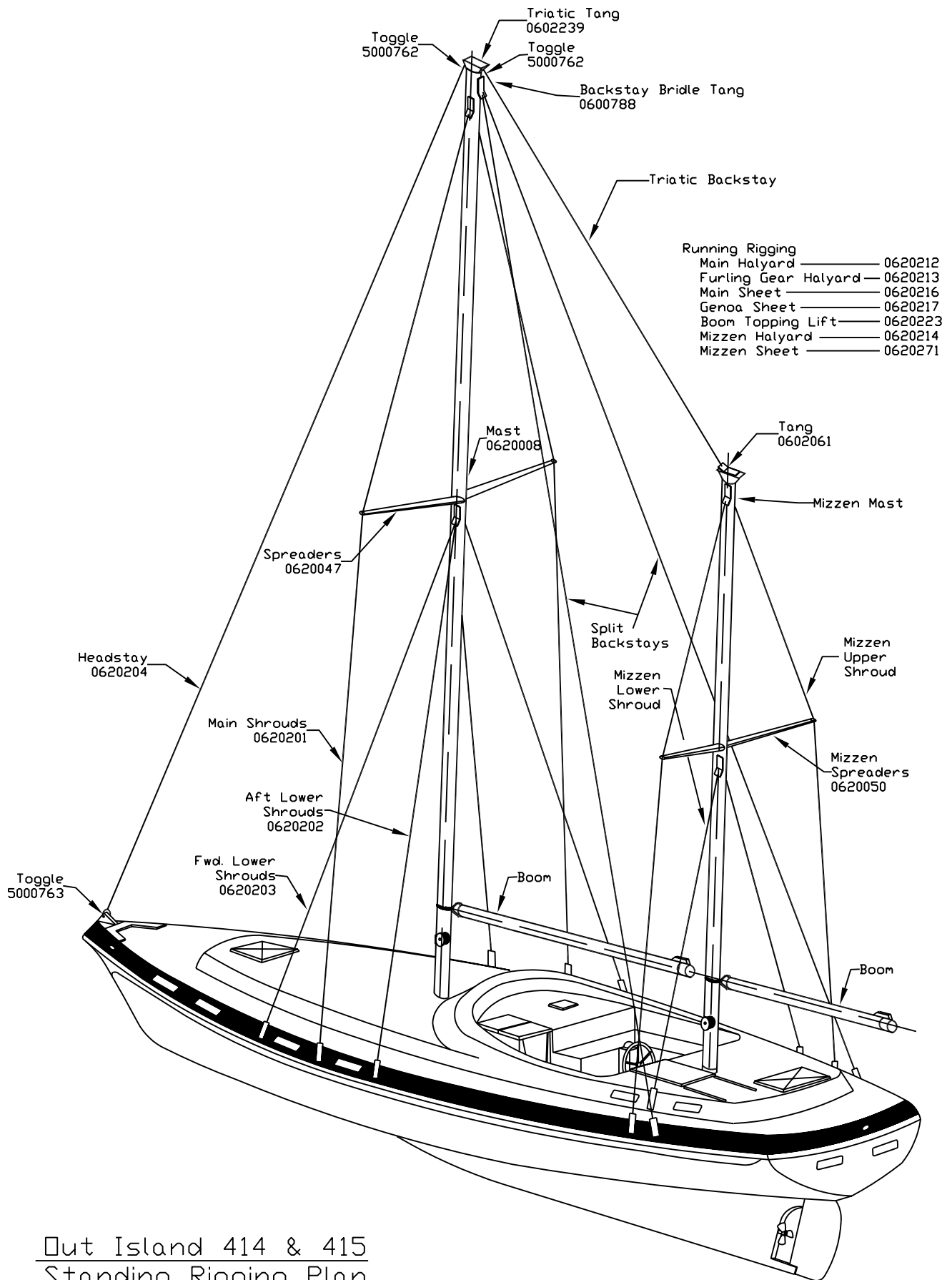

Out Island 414 & 415
Standing Rigging Plan
Ketch Rig

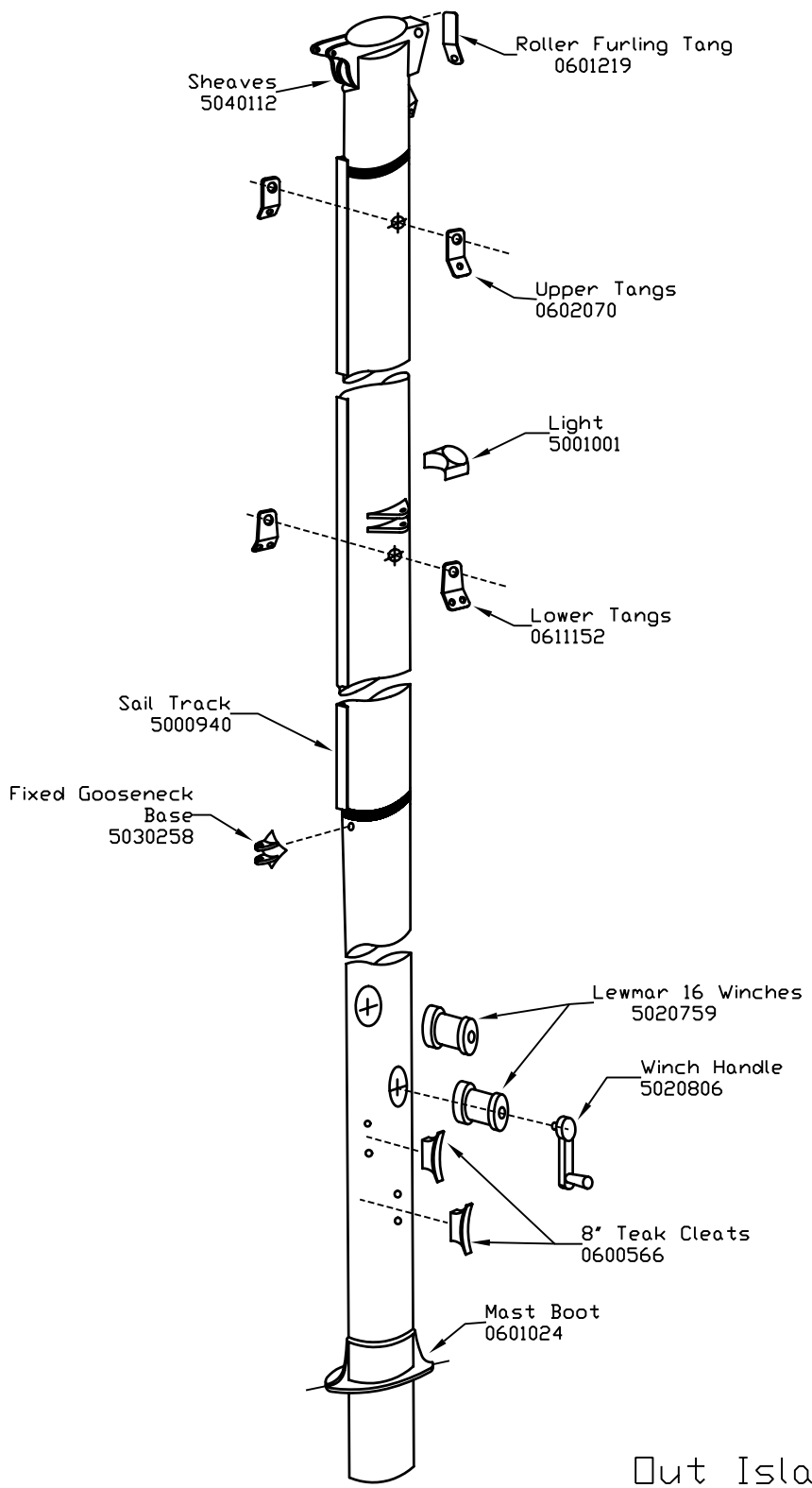

Out Island 414 & 415

 Mast Assembly
 0620008

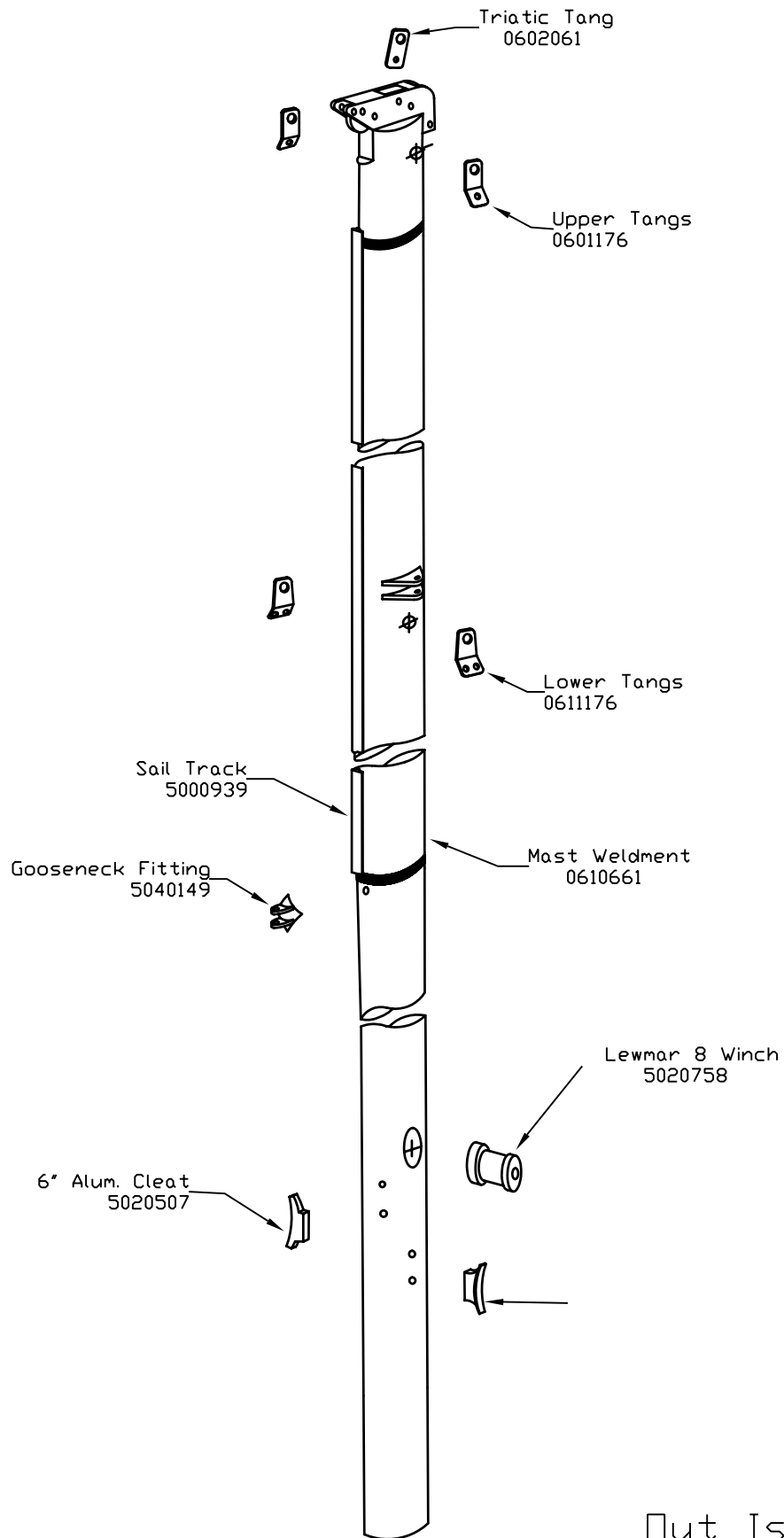

Out Island 414 & 415
Mizzen Mast Assembly

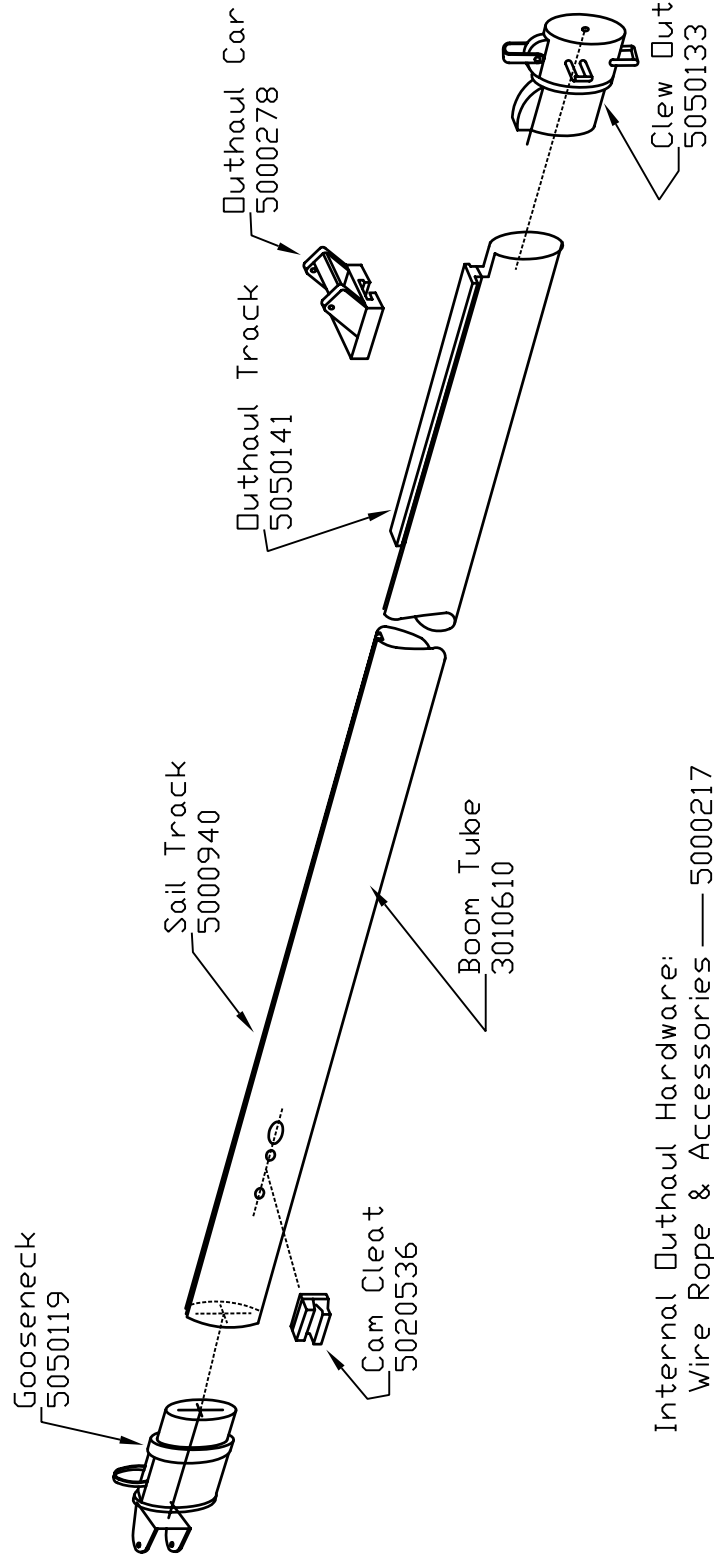

- Internal Duthaul Hardware:
- Wire Rope & Accessories — 5000217
 - 5000524
 - 5000869
 - Intrepid Braid Rope — 5001025
 - Block 04-43 — 5000635
 - Block 04-52 — 5000636

Out Island 414 & 415
 Boom Assembly
 0620027

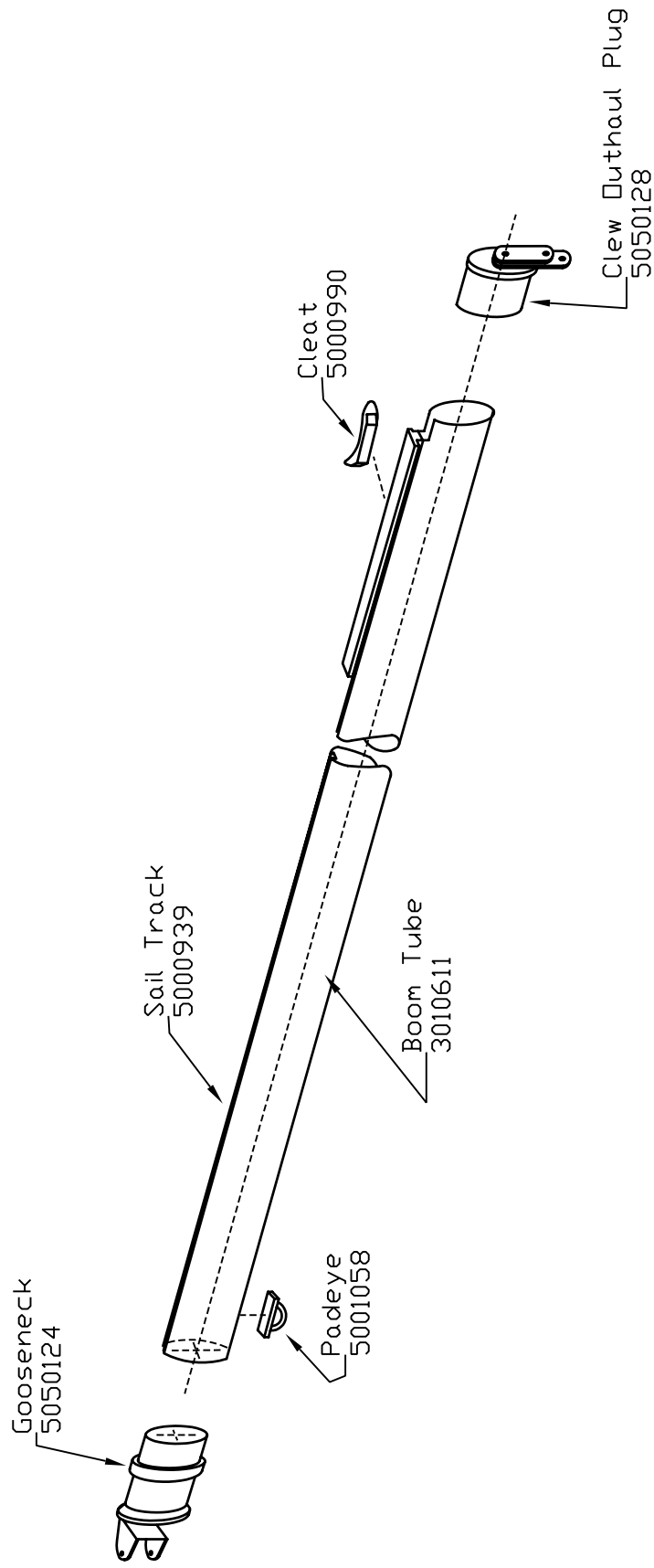

Out Island 414 & 415
Mizzen Boom Assembly
0620029

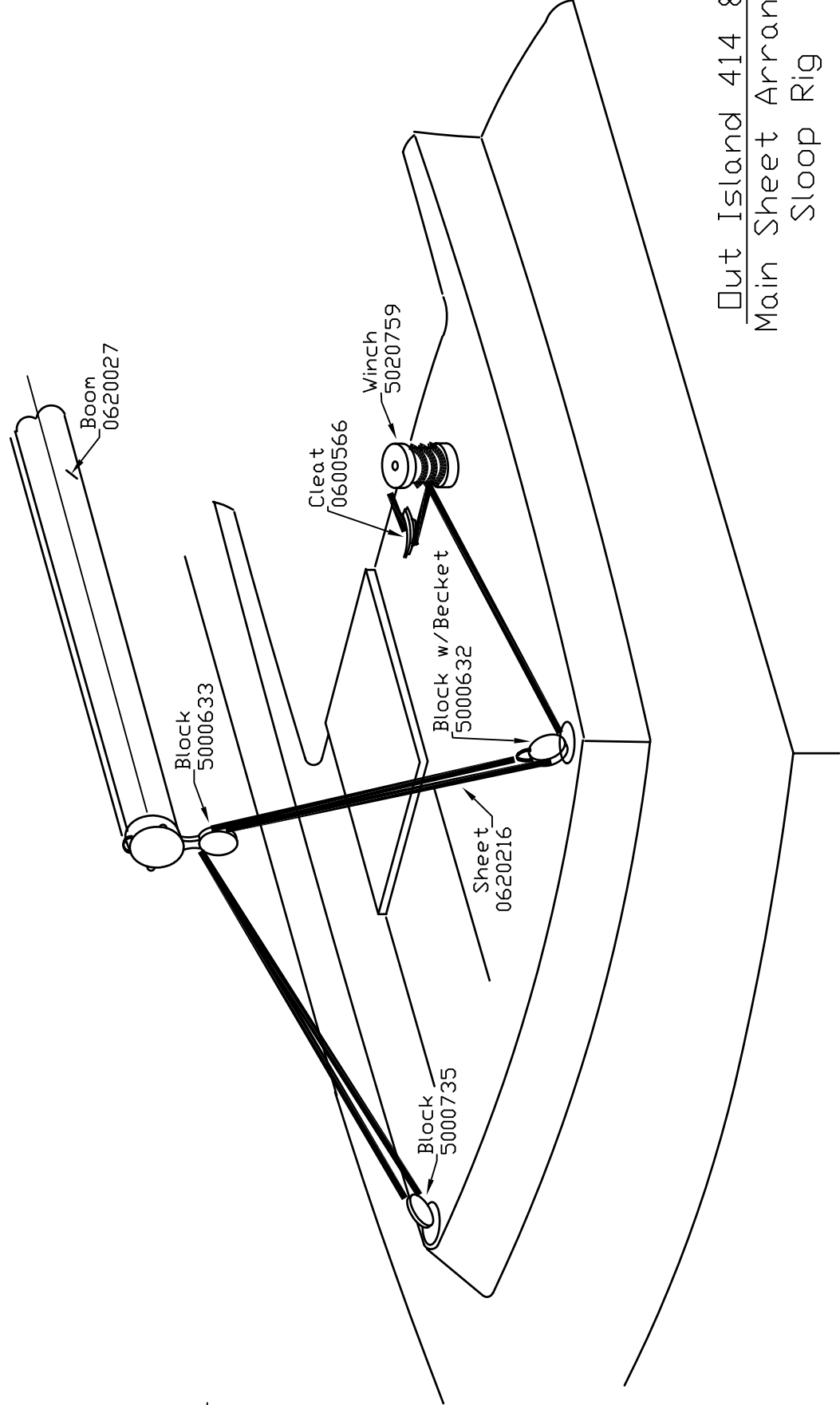

Out Island 414 & 415
Main Sheet Arrangement
Sloop Rig

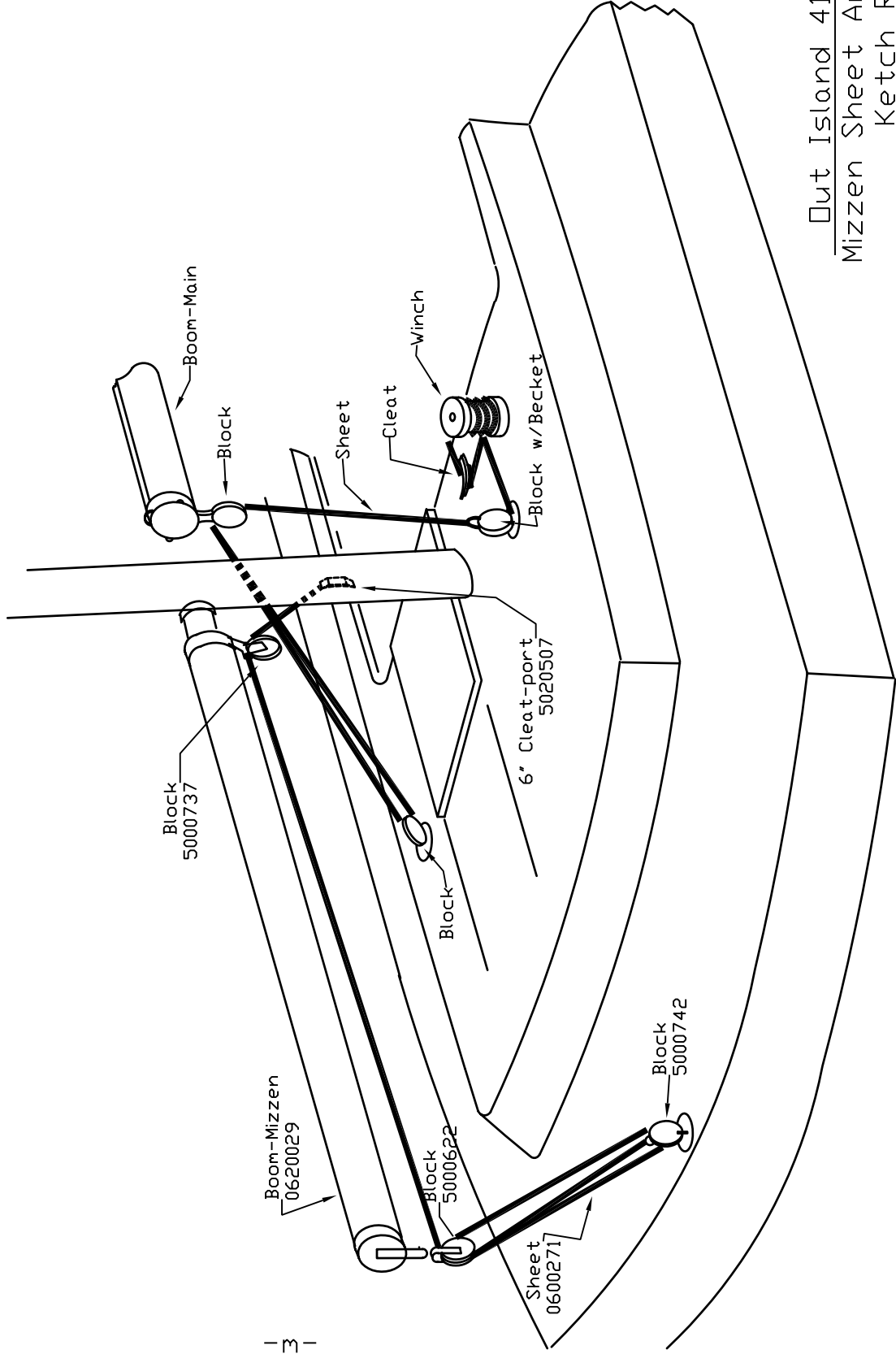

Out Island 414 & 415
 Mizzen Sheet Arrangement
 Ketch Rig

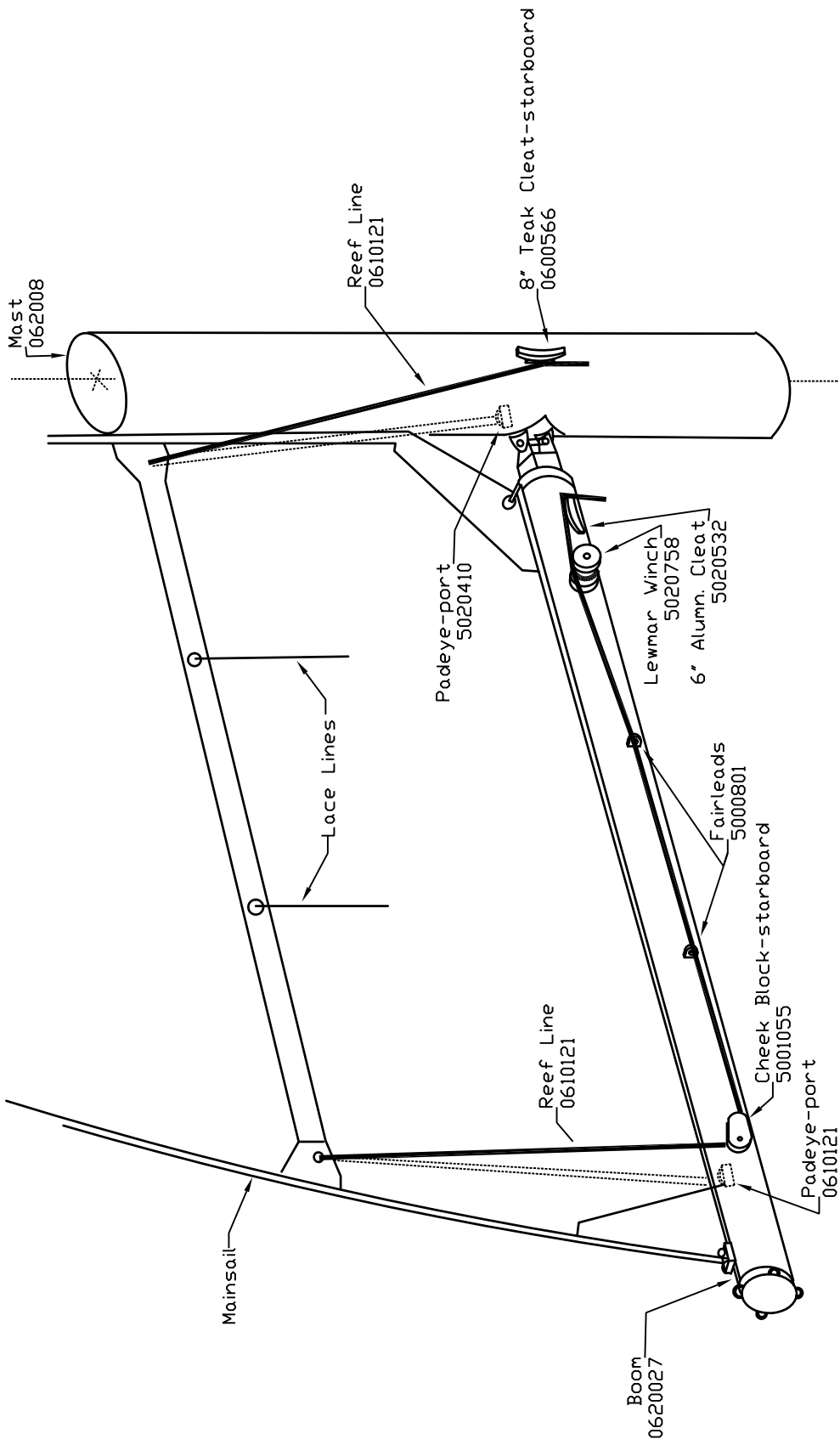

Out Island 414 & 415
Quick Reefing System

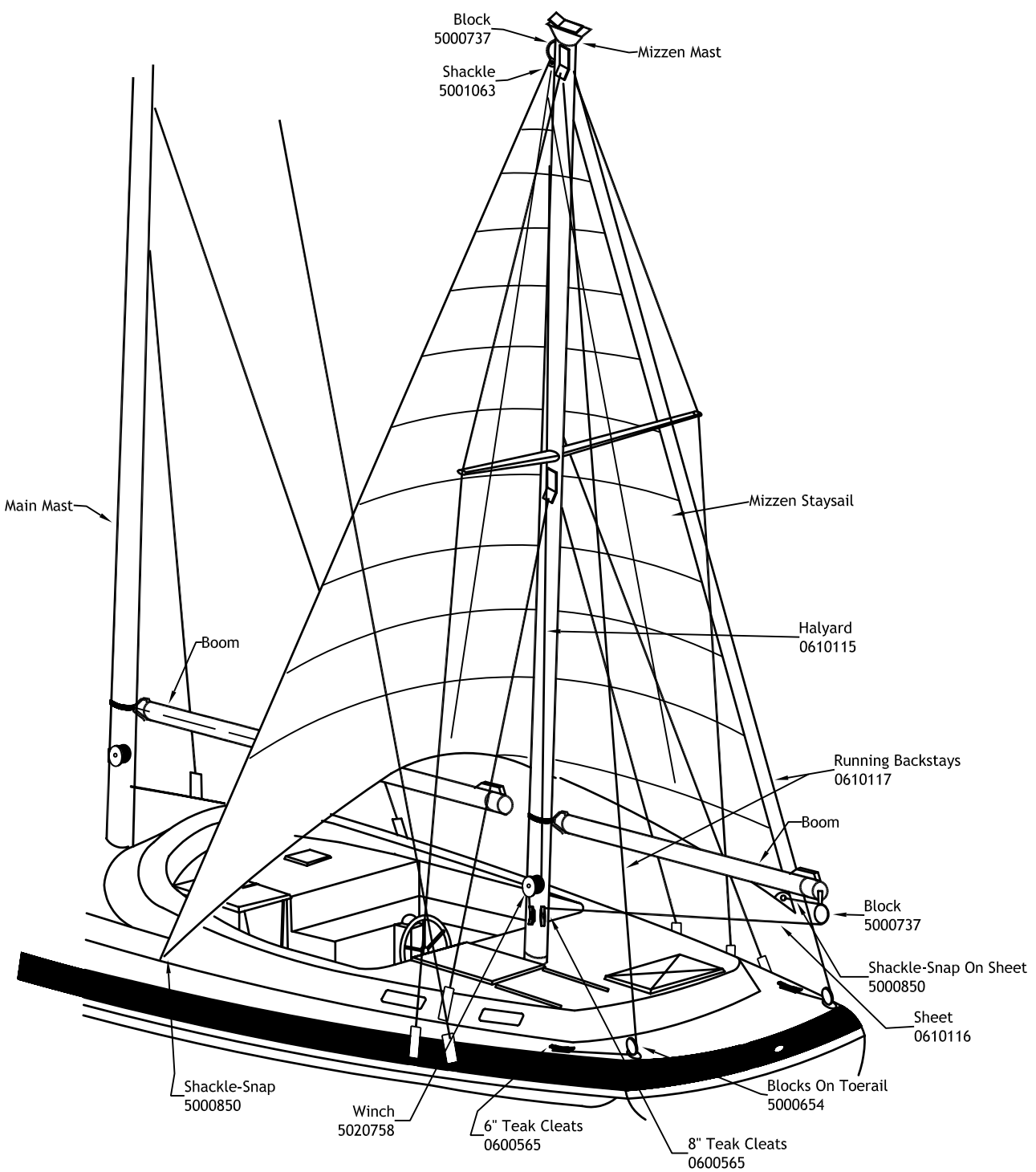

**Out Island 414 & 415
Mizzen Staysail Package**

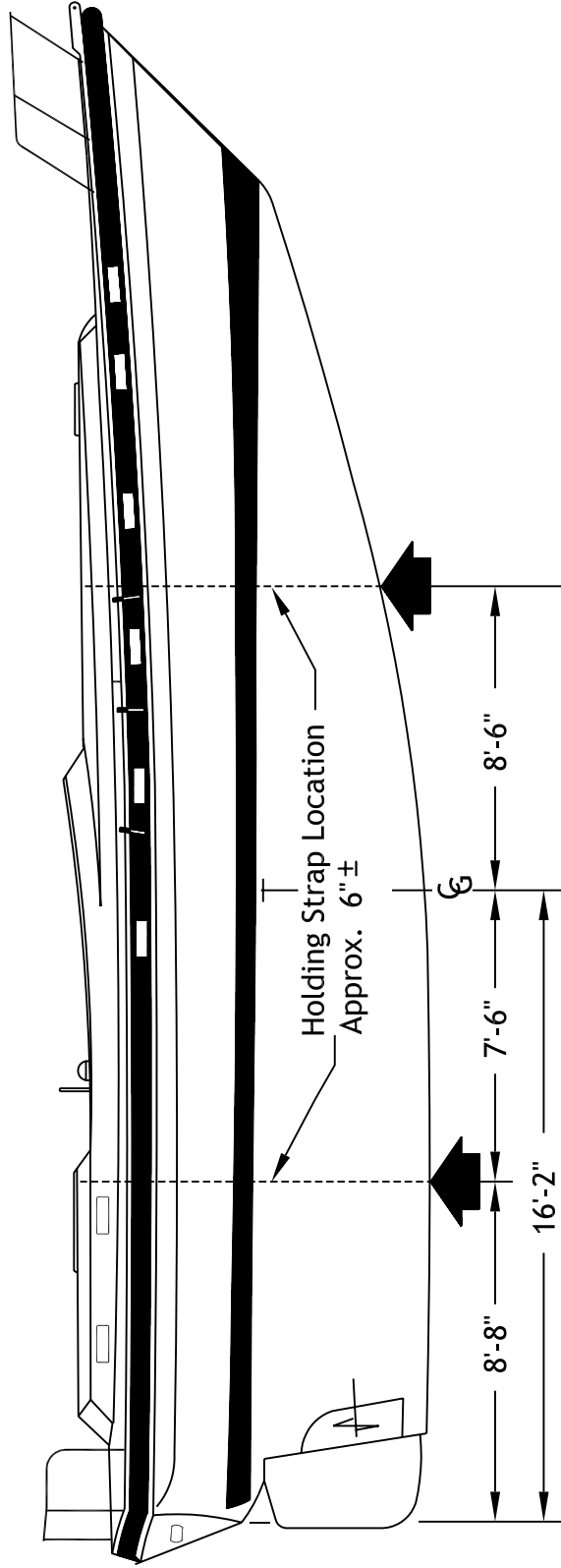

Out Island 414 & 415
Hauling Diagram

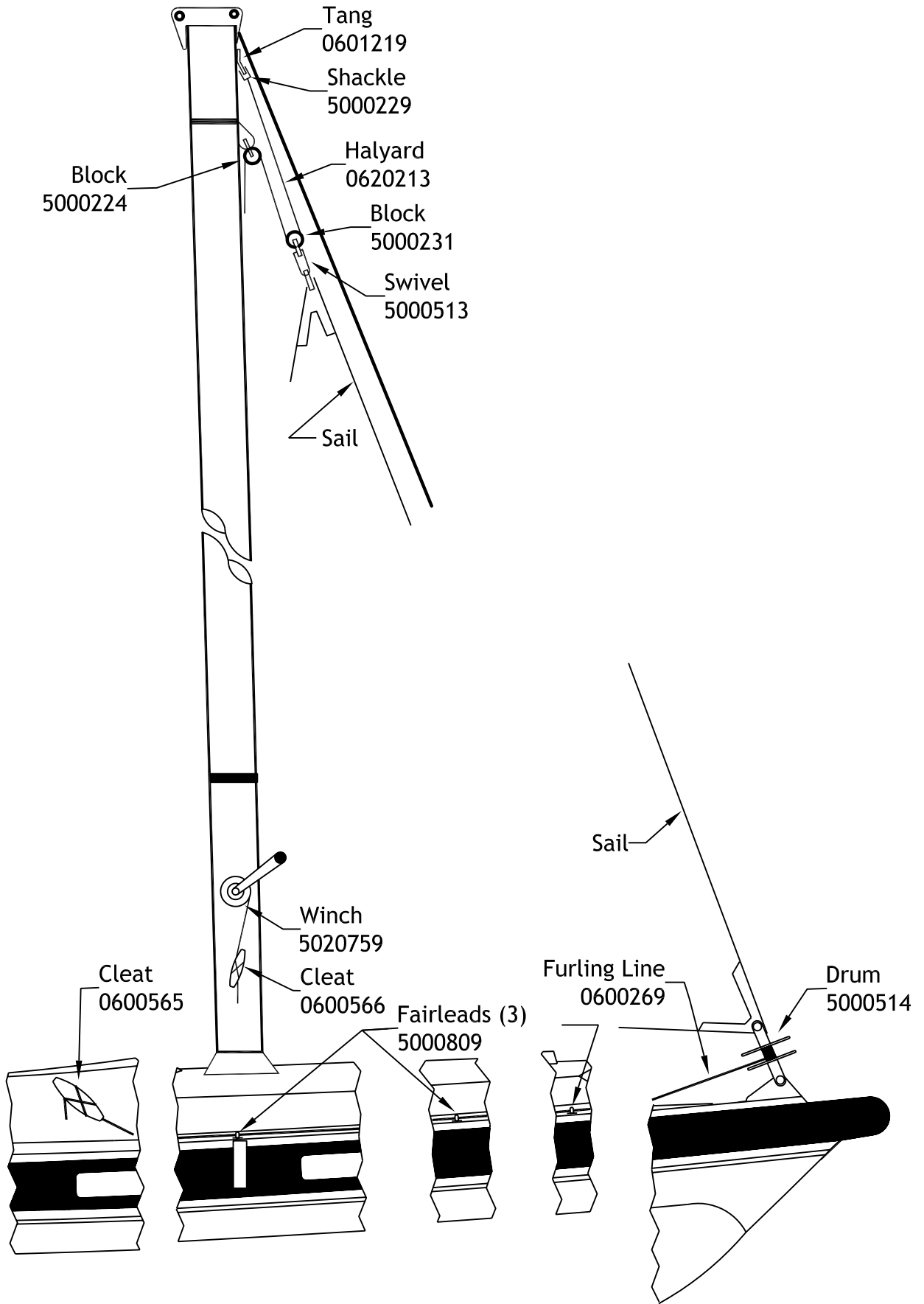

Out Island 414 & 415
Jib Roller Furling Gear

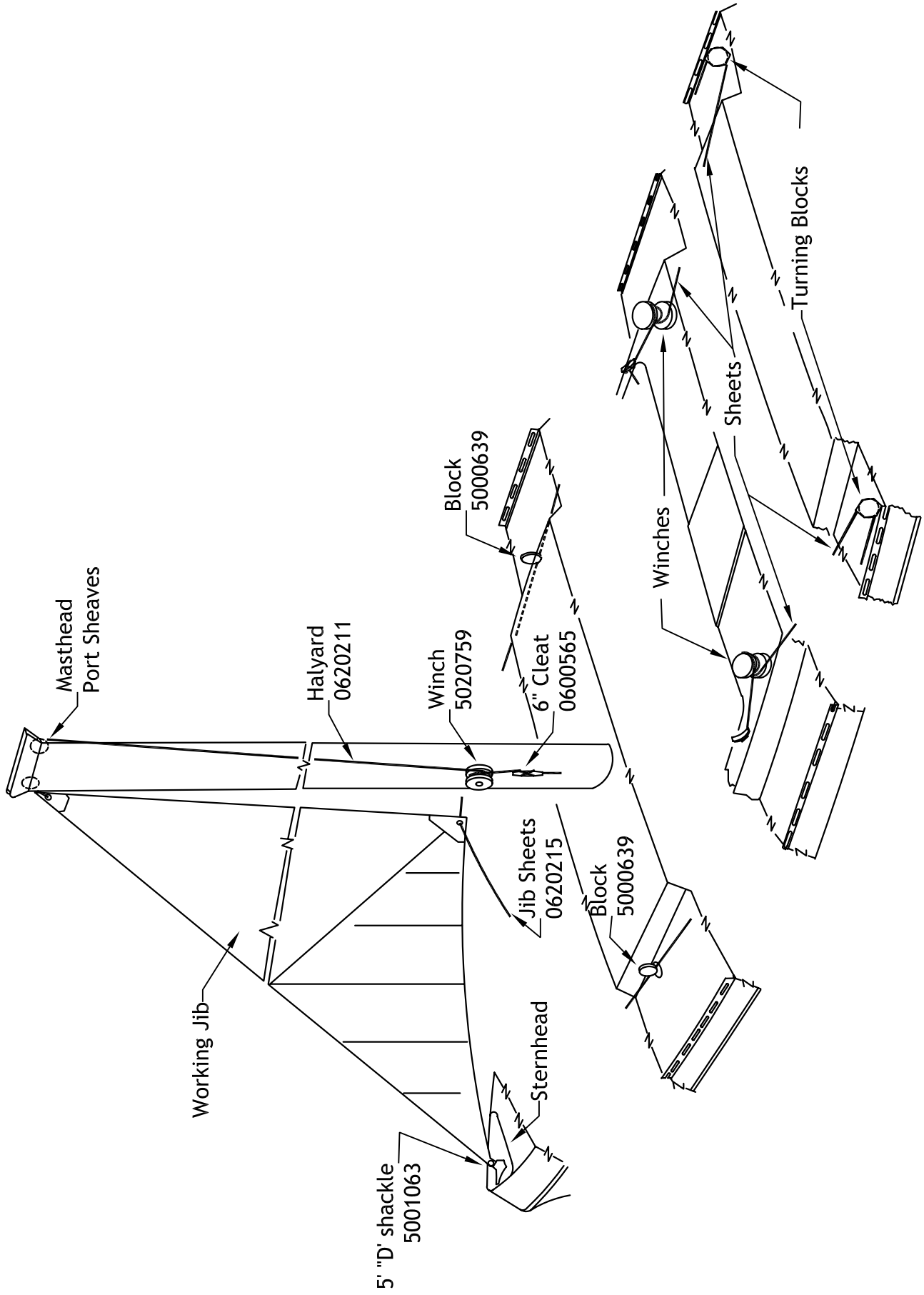

-r-

Out Island 414 & 415
 Working Jib Hardware Package

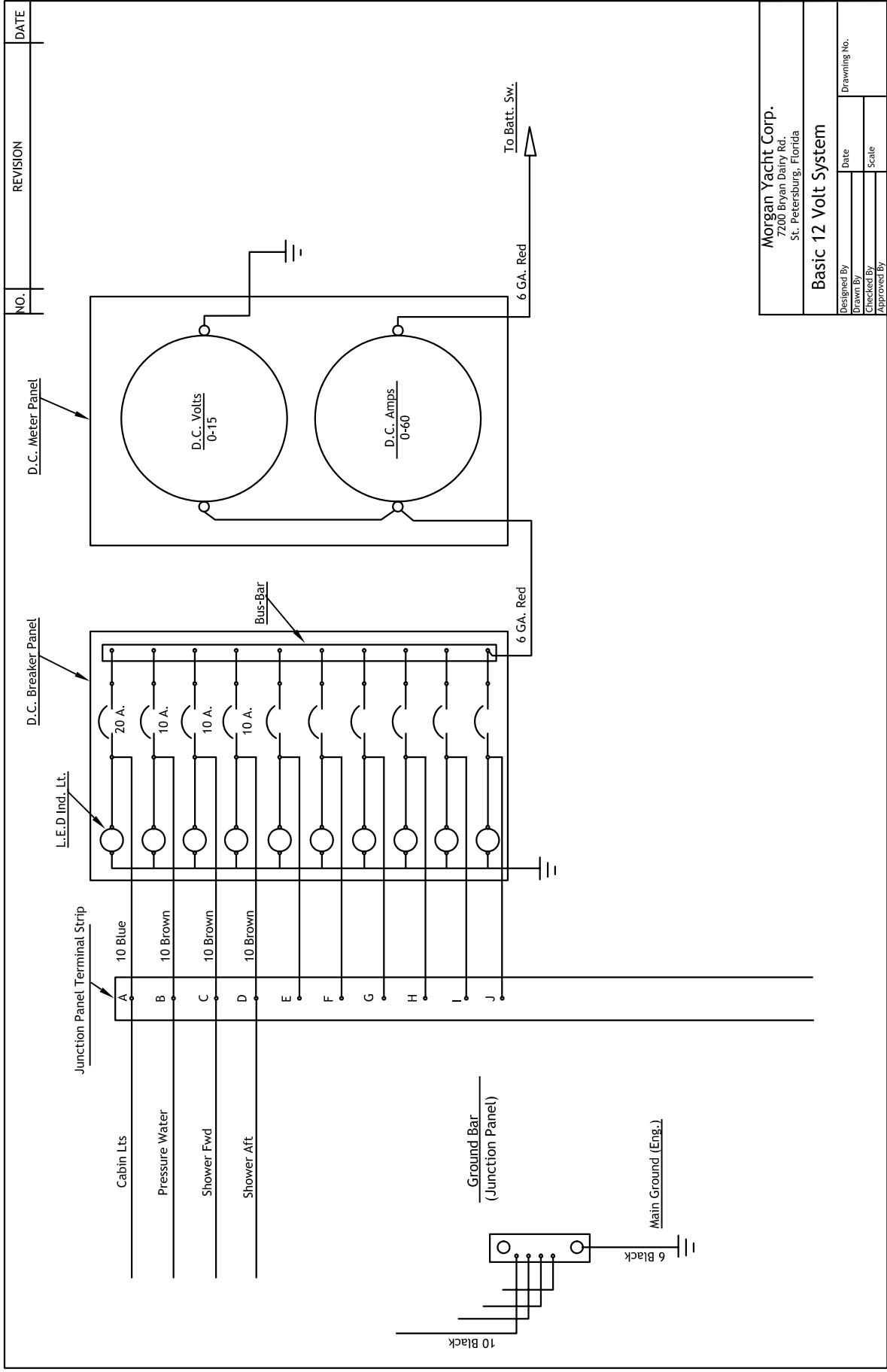

NO.	REVISION	DATE
-----	----------	------

Morgan Yacht Corp. 7200 Bryan Dairy Rd. St. Petersburg, Florida	
Basic 12 Volt System	
Designed By	Drawing No.
Drawn By	Date
Checked By	Scale
Approved By	

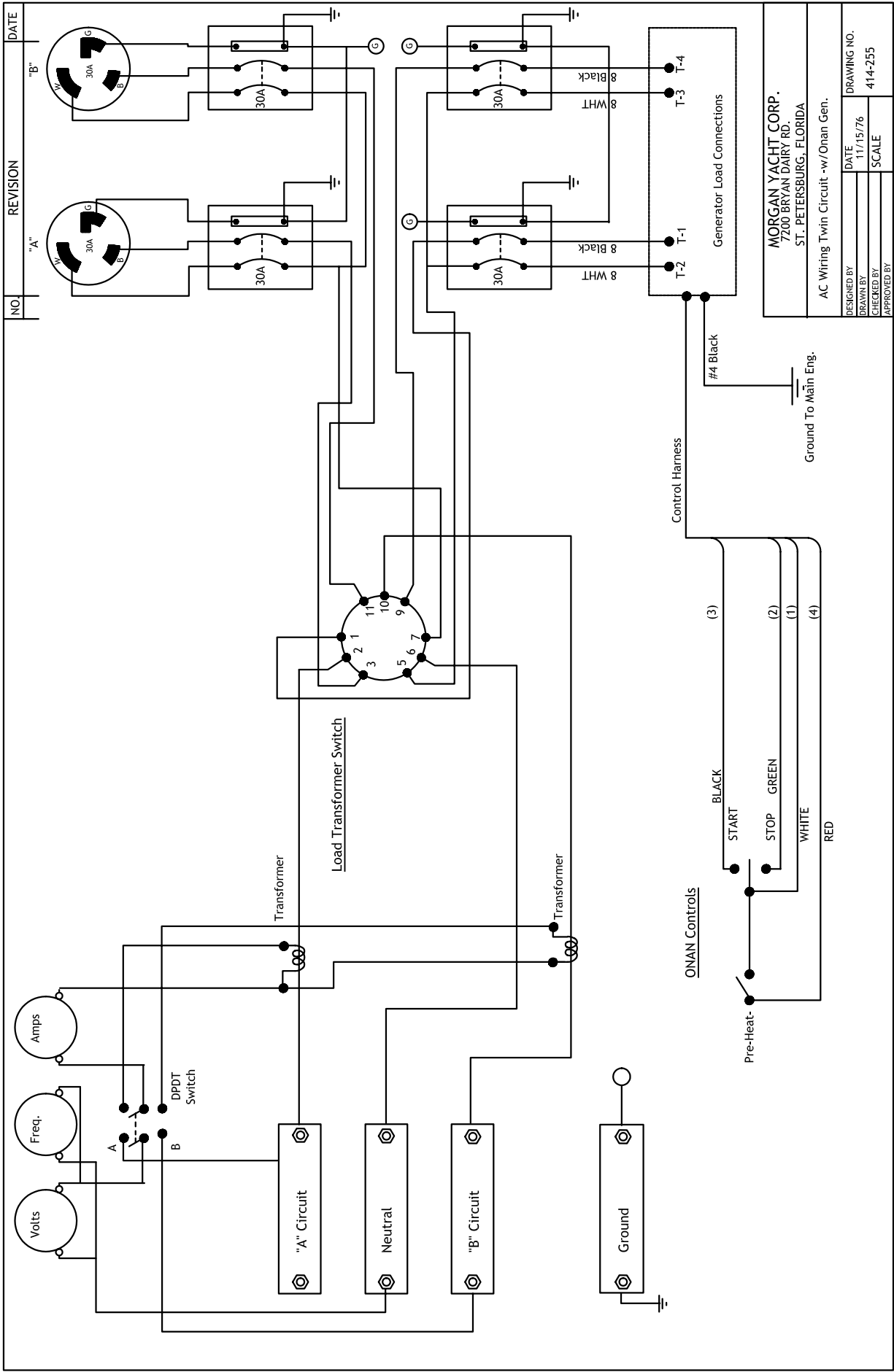

NO.	REVISION	DATE
	"A"	
	"B"	

MORGAN YACHT CORP.
 7200 BRYAN DAIRY RD.
 ST. PETERSBURG, FLORIDA

AC Wiring Twin Circuit -w/Onan Gen.

DESIGNED BY	DATE	DRAWING NO.
DRAWN BY	11/15/76	414-255
CHECKED BY	SCALE	
APPROVED BY		

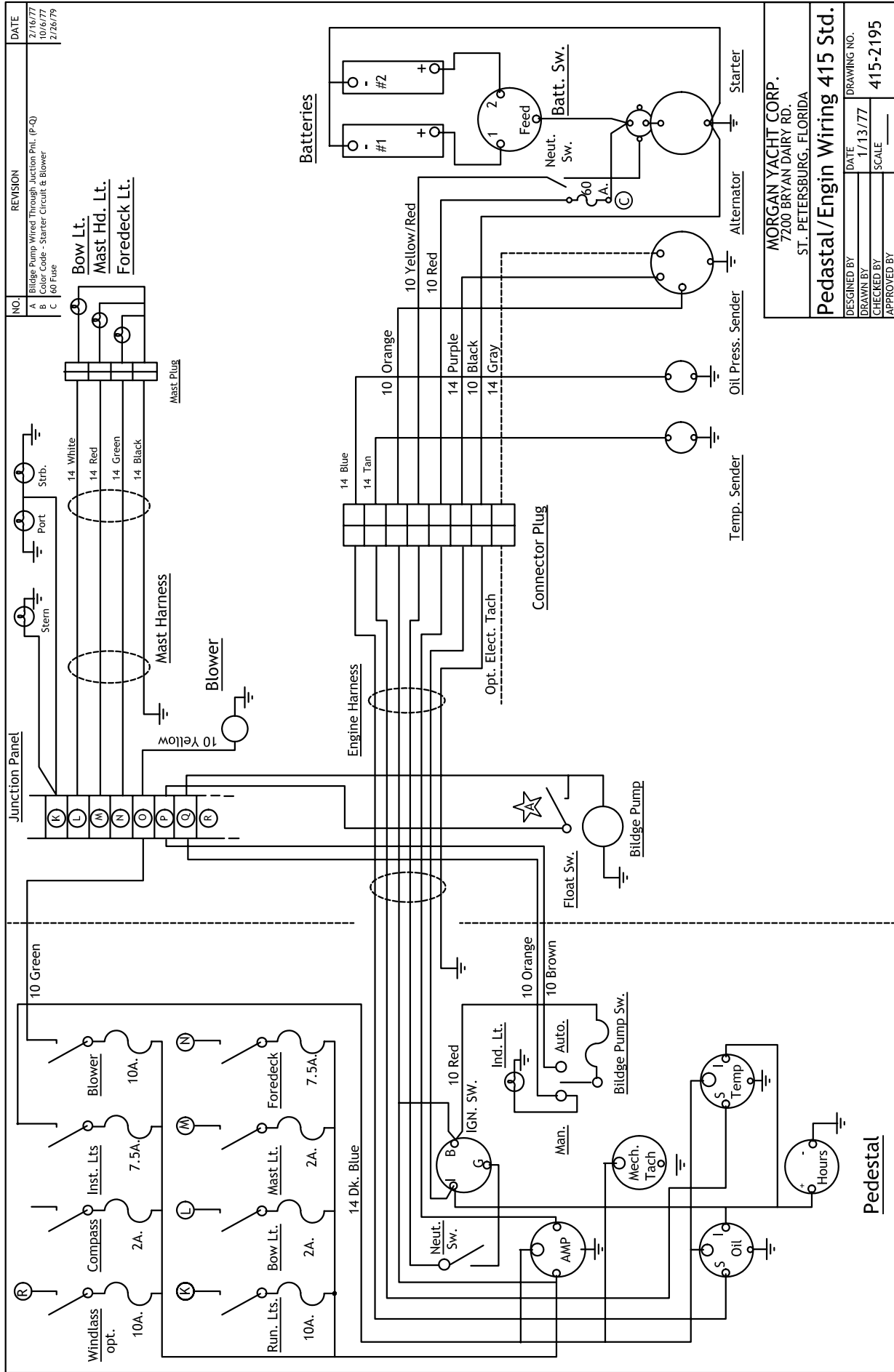

NO.	REVISION	DATE
A	Bidge Pump Wired Through Junction Pnl. (P-Q)	2/16/77
B	Color Code - Starter Circuit & Blower	10/6/77
C	60 Fuse	2/26/79

MORGAN YACHT CORP. 7200 BRYAN DAIRY RD. ST. PETERSBURG, FLORIDA	
Pedestal/Engine Wiring 415 Std.	
DESIGNED BY	DRAWING NO.
DRAWN BY	DATE
CHECKED BY	1/13/77
APPROVED BY	SCALE
	415-2195

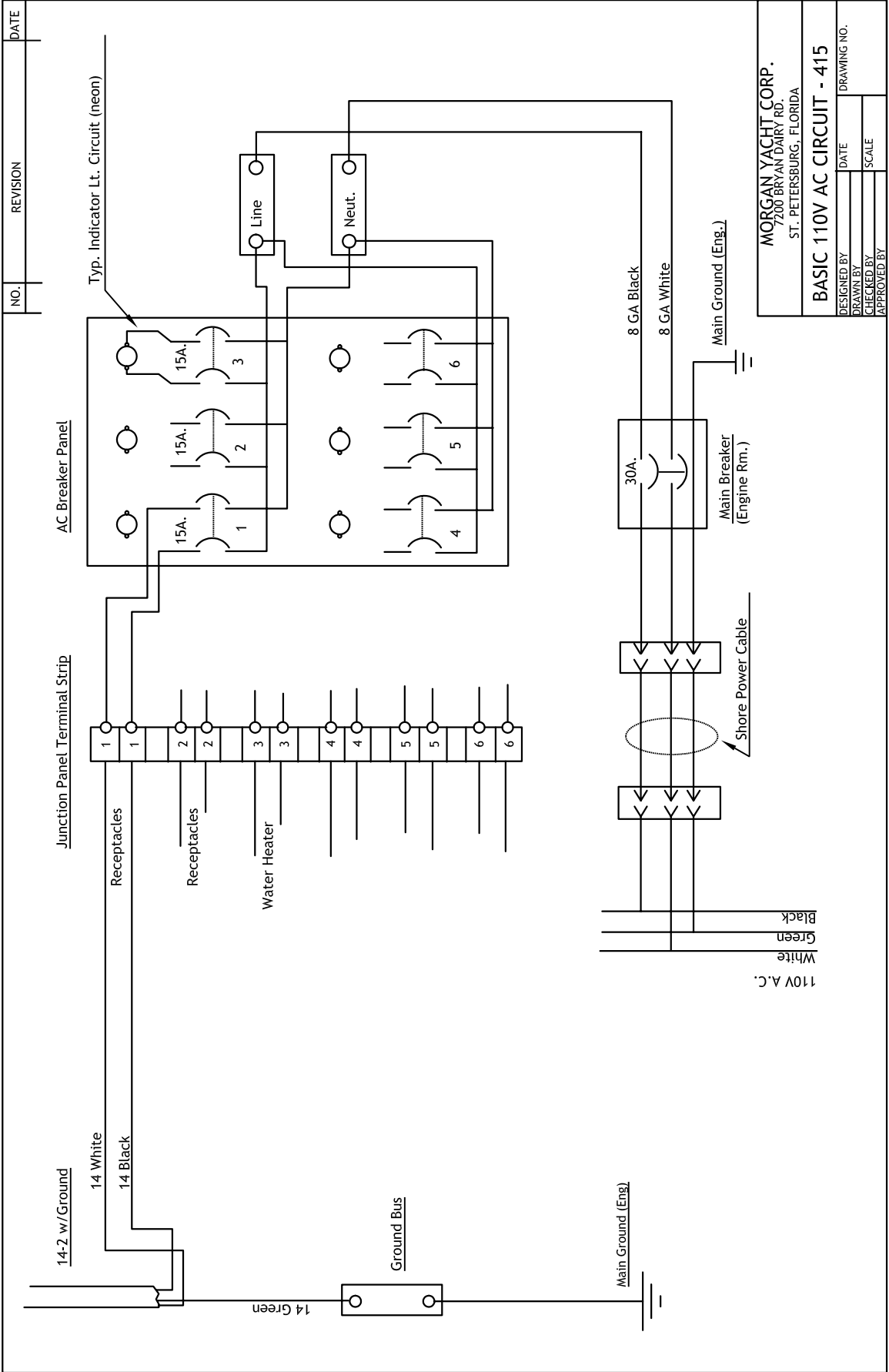

MORGAN YACHT CORP.
7200 BRYAN DAIRY RD.
ST. PETERSBURG, FLORIDA

BASIC 110V AC CIRCUIT - 415

DESIGNED BY	DATE	DRAWING NO.	
DRAWN BY			
CHECKED BY			SCALE
APPROVED BY			

NO.	REVISION	DATE

NO.	REVISION	DATE

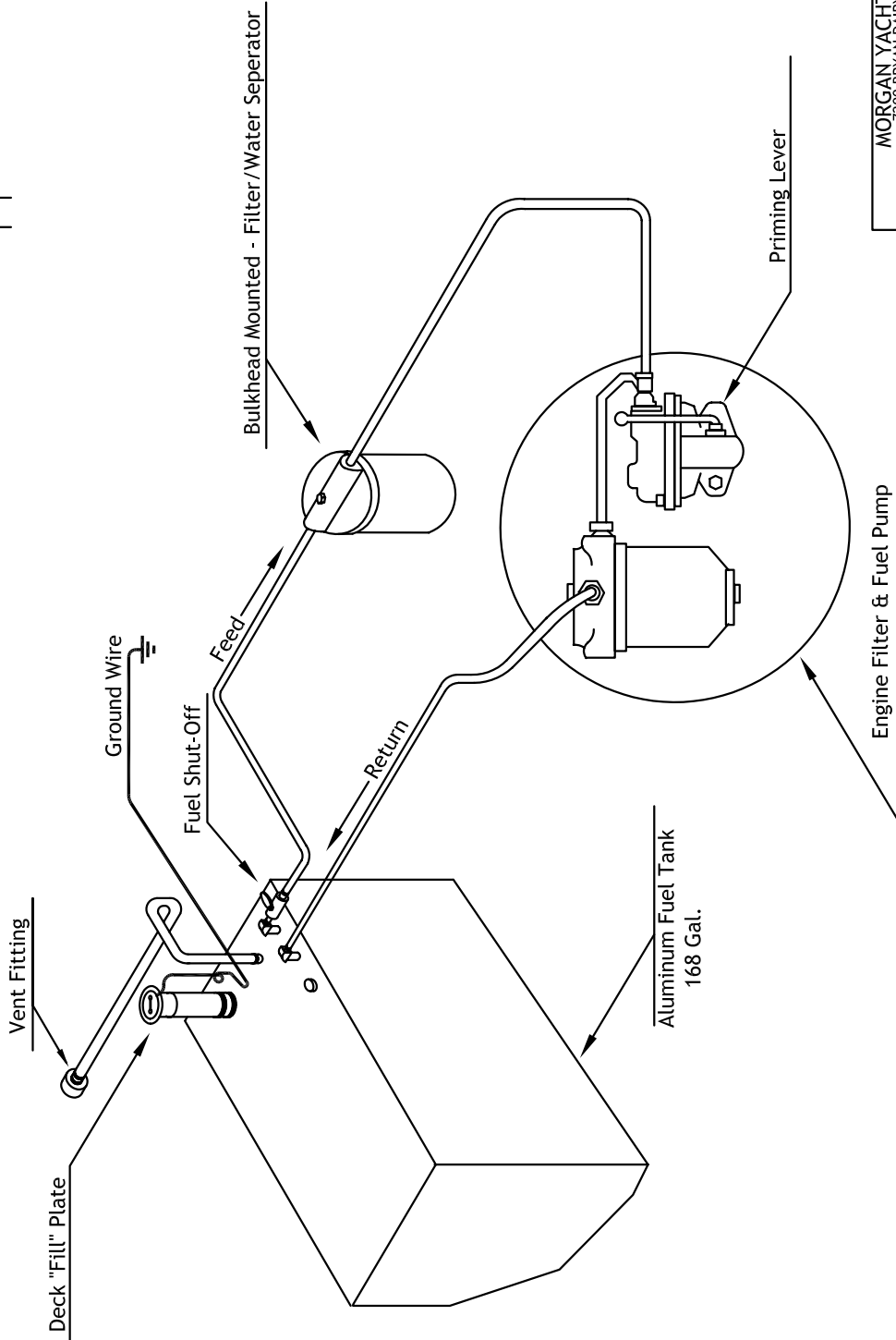

MORGAN YACHT CORP. 7200 BRYAN DAIRY RD. ST. PETERSBURG, FLORIDA	
Fuel System 414 Std.	
DESIGNED BY	DRAWING NO. 414-257
DRAWN BY	DATE 12/18/76
CHECKED BY	SCALE
APPROVED BY	

No.	REVISION	DATE
-----	----------	------

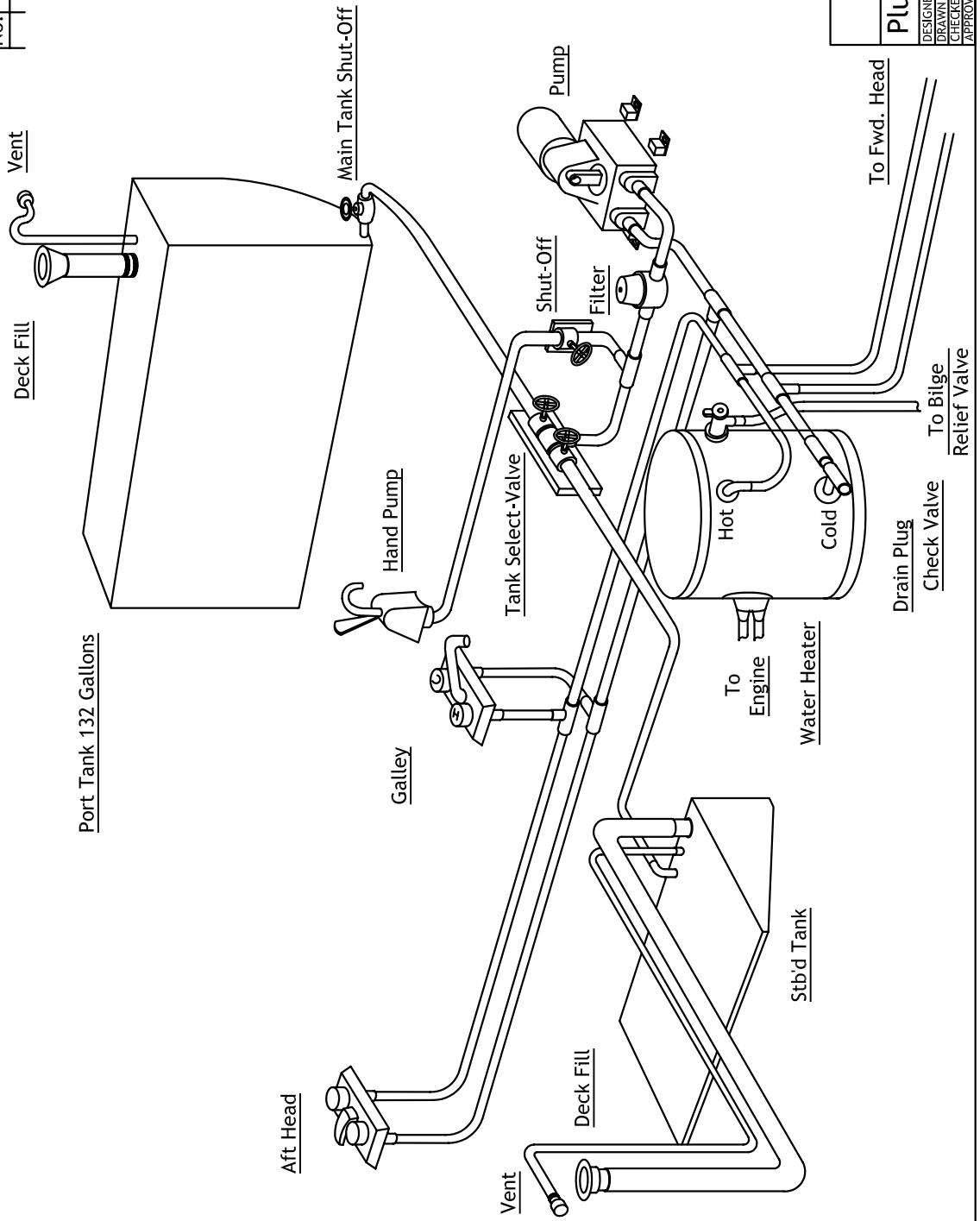

MORGAN YACHT CORP.
7200 BRYAN DAIRY RD.
ST. PETERSBURG, FLORIDA

Plumbing Layout 415

DESIGNED BY	DATE	DRAWING NO.
DRAWN BY		415-2165
CHECKED BY	SCALE	
APPROVED BY		

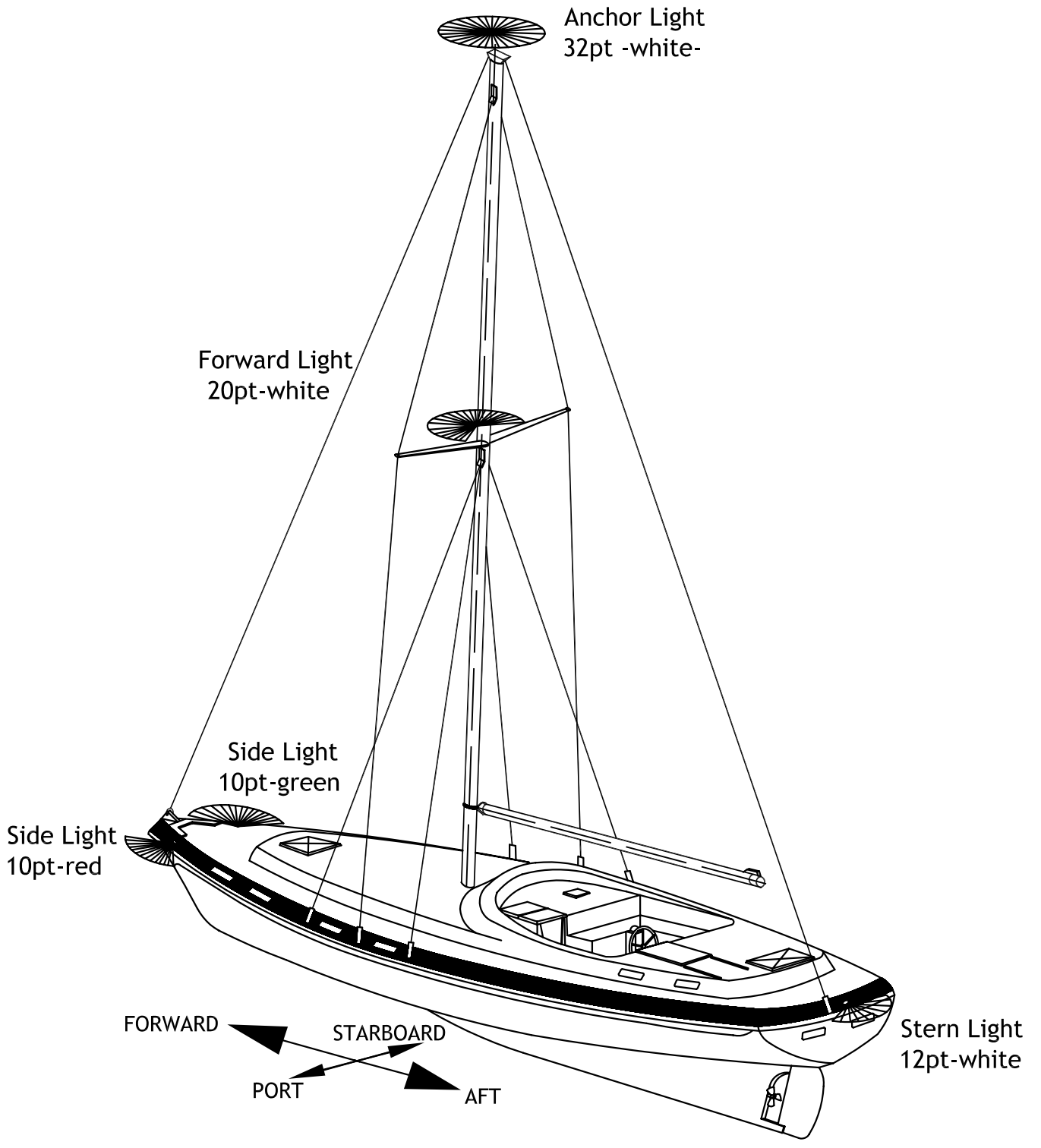

Navigation Lights

ELECTRICAL - MAJOR COMPONENTS

- Ⓐ Main Panel
- Ⓑ Junction Panel
- Ⓒ Main Battery Switch
- Ⓓ Auto. Bilge Pump
- Ⓔ Press. Water Pump
- Ⓕ Shower Sump Pump
- Ⓖ Shower Sump Pump
- Ⓜ Main Batteries
- Ⓨ Blower (Eng.)
- Ⓚ Pedestal Controls
- Ⓛ Batt. Chg. (Opt)
- Ⓜ Main A. C. Brk
- Ⓝ Water Heater
- Ⓝ Water Tank

MECHANICAL - MISC. COMPONENTS

- Ⓛ Man. Bilge Pump (Opt)
- Ⓖ Hyd Strg. Reservoir
- Ⓝ Ice Box Drain Pump
- Ⓛ Shaft Center Brg.
- Ⓟ Alcohol Tank
- Ⓝ Water Tank Shut Off
- Ⓡ Water Tank Select Valve

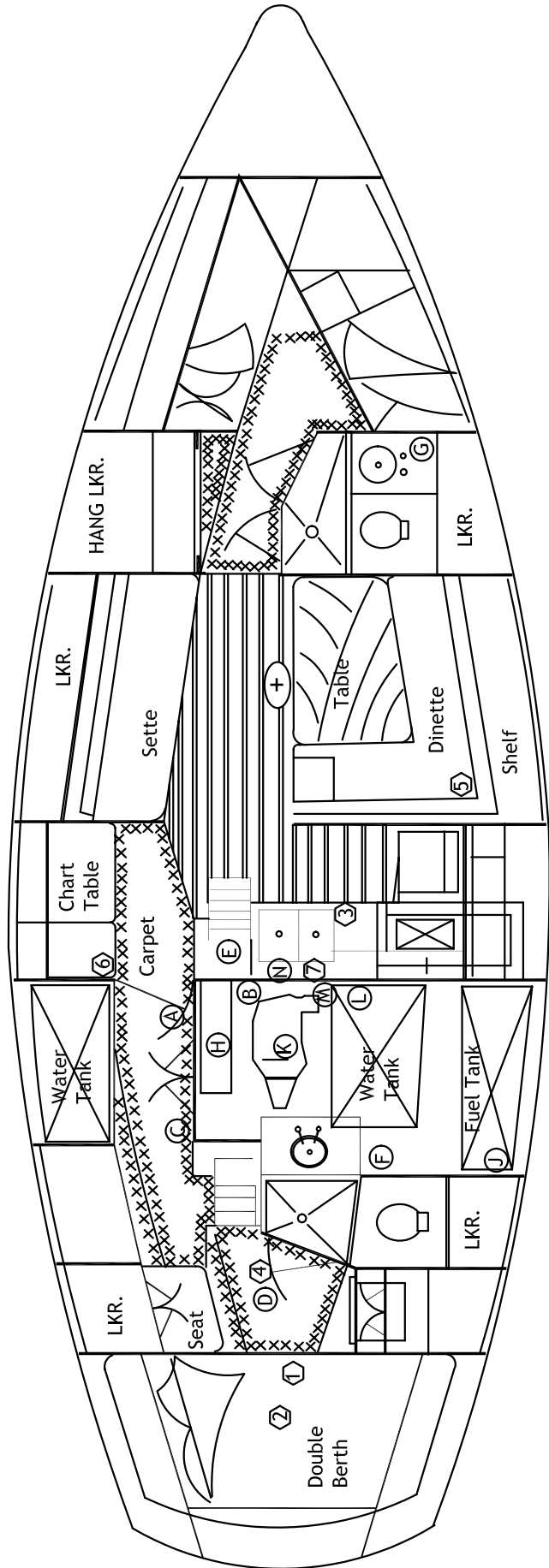

415 - TERMINAL IDENTIFICATION

D.C.

- A - Cabin Lights
- B - Pressure Water
- C - Shower Fwd.
- F - Shower Aft
- E -
- F -
- G -
- H -
- I -
- J -
- K - Running Lights
- L - Bow Lights
- M - Masthead Lights
- N - Foredeck Lights
- O - Engine Blower
- P - Bilge Pump - Auto.
- Q - Bilge Pump - Man.
- R - Windlass
- S - Generator - Blower
- T - Generator - Blower Solenoid
- U - Generator - Pre-heat
- V - Generator - Start
- W - Generator - Stop
- X - Generator - Negative

REQUIRED SAFETY EQUIPMENT

The yacht owner should reference the U.S. Coast Guard and/or the controlling body and codes for his area of operation. The following information is listed for your convenience, but should not be misconstrued as complete.

Navigation Lights

Per U.S.C.G. International rules, Inland rules, or governing codes for operational area.

Life Preservers

Shall be of approved type. Class 3 vessels (Out Island 41), if not carrying passengers for hire, shall carry an approved life preserver (Type I, II, or III) for each person on board plus one Type IV (buoyant cushion, life ring buoy, or throwable special purpose water safety buoyant device) available to be thrown. Storage of the above equipment shall be so placed as to be readily accessible. Note: Work vests (Type V) are not acceptable as part of the above requirements.

Fire Extinguishing Equipment

Shall be of an approved type. The Class 3 vessel requires three Type B-1 extinguishers (1 ¼ gals.-foam; 4 lbs.-carbon dioxide; or 2 lbs.-dry chemical), or one Type B-II (2 ½ gals.-foam; 15 lbs.-carbon dioxide; or 10 lbs. dry chemical) extinguishers; if the vessel has no fixed fire extinguishing system in the machinery space. It requires two Type B-I or one Type B-II extinguishers if a fixed is installed in the machinery space.

Ventilation

Ventilation of machinery spaces containing the engine and/or tanks shall be accomplished with a minimum of one air intake duct, and one exhaust duct. The exhaust duct shall extend from the atmosphere to the lower portion of the bilge. The intake duct shall be installed so as to extend at least to the midpoint to bilge, below the carburetor intake, and to the atmosphere. The cowls shall be such that displaced fumes cannot be recirculated. The vents should not be closed at any time.

Whistles

One power operated whistle, capable of producing a blast audible at a distance of at least one mile, and with blasts of at least two seconds duration.

Bell

If operating in water subject to the rules of the road, you must carry an efficient fog bell.

The above information is taken from the Coast Guard Publication of "Rules and Regulations for Uninspected Vessels," Subchapter C, May 1, 1970, Ref. CG-258, reflecting the minimums.

Recommendations by ABYC and boating manuals may be more strenuous, and should be followed at the owner's option.

Distress signals, (Flares, smoke signals, dye markers, signaling mirror and/or orange flag) while not required, are strongly recommended.

The yachtsman should become totally familiar with the "Rules of the Road" for his particular area. We suggest a publication like, "Piloting Seamanship and Small Boat Handling" by Chapman, for additional recommended equipment, their proper use, and conditions of operation.

TABLE OF FUSES AND BULBS

Fuses used in Out Island 41 (Model 415):

Running Lights	10 amp in-line buss
Bow Light	2 amp in-line buss
Foredeck Light	7.5 amp in-line buss
Masthead Light	2 amp in-line buss
Bilge Pump	7.5 amp in-line buss
Blower	10 amp in-line buss
Instrument Lights	7.5 amp in-line buss
Compass	2 amp in-line buss
Engine Circuit	60 amp in-line buss

Lights used in Out Island 41 (Model 415):

Instruments	W-ST (12V)
Tachometer	GE-16100 (12V)
Bow Light	12V 6CP (GE #90)
Foredeck Light	T 3606 E
Masthead Light	(12V) GE #90
Stern Light	1416 (12V)
Running Lights	12V 10W #1004
Chart Table Light	T3 ¼ #1487
	Rival 12V 6W
High Intensity Reading Light	W1383 (12V)
Small Guest Light	W1142 (12V)
Large Guest Light	25 watt 12V
Single Rectangular Light	#93 (12V)
Double Rectangular Light	#93 (12V)
12" Fluorescent	F8T5-CW 12V
Engine Room Light	GE #90 12V 6CP